



**POWER SOLUTIONS
INTERNATIONAL**

POWER SYSTEMS PRODUCT GUIDE



WHO IS PSI?

Power Solutions International, Inc. is a leader in the design, engineering and manufacture of emissions-certified, alternative-fuel power systems. PSI provides integrated turnkey solutions to leading global original equipment manufacturers in the industrial and on-road markets. The company's unique in-house design, prototyping, engineering and testing capacities allow PSI to customize clean, high-performance engines that run on a wide variety of fuels, including natural gas, propane, wellhead, biogas, gasoline and diesel.

PSI is at the forefront of innovation, specializing in the development and delivery of comprehensive industrial power solutions. The offerings extend globally, encompassing stationary and mobile power generation systems catering to a variety of needs such as standby, prime, distributed generation, demand response, and co-generation power (CHP) applications. Furthermore, expertise is evident in contributions to mobile industrial sectors, providing tailored solutions for a diverse range of equipment including forklifts, aerial lifts, industrial sweepers, aircraft ground support, arbor care, agricultural machinery, and construction equipment. Additionally, PSI is in designing and delivering powertrains specifically engineered for Class 3 through Class 7 medium-duty trucks and buses. The focus spans across the North American and Asian markets, meeting the unique requirements of work trucks, school buses, transit buses, terminal tractors, and various other vocational vehicles.



TABLE OF CONTENTS

| | |
|--|----|
| Emissions Regulations & Certifications | 2 |
| Customer Support | 3 |
| Engine Rating Guidelines & Conversions | 4 |
| Gas Engine Products | |
| 50Hz Ratings | 7 |
| 60Hz Ratings | 8 |
| Product Listings | 9 |
| Diesel Engine Products | |
| 60Hz Ratings | 34 |
| Product Listings | 35 |
| Engine Controls | 42 |
| Global Network | 44 |

EMISSIONS REGULATIONS & CERTIFICATIONS

All of our gas engines are U.S. EPA factory certified and are qualified to meet New Source Performance Standards (NSPS) NOx emissions requirements without the addition of an aftertreatment system. PSI products are capable of compliance with UL2200, NFPA 110, and ISO8528. Should your application or area demand stricter standards, our team can tailor a solution to meet those needs.

What Certifications Do PSI Models Have?

- U.S. EPA-Certified and CARB-Compliant
- UL2200-Compliant or Listed Components
- CSA Certification

EPA certification covers both stationary and non-road applications for constant speed operation on pipeline quality natural gas (CNG/LNG) and propane (LPG). PSI's expanded family of Heavy Duty engines range from 4.5-liters to 53-liters of displacement up to 1.25 MWe of natural gas power."

CUSTOMER SUPPORT

We're committed to expanding your line of defense against power failures. Whether you're adding new units or servicing your existing products, we have a solution to match your application and standards. PSI will help you select the right product for your application and install and maintain your system.

- Customer Support Agreements
- Parts Availability and Parts Stocking Strategy
- Preventative Maintenance Schedules

Technical Support Hotline: 1.888.331.5764

Email: service@psiengines.com

ENGINE RATING GUIDELINES

PSI HEAVY-DUTY TECHNICAL STANDARD 56100017

Standby Power

Capable of supplying emergency power for the duration of a utility power outage. Typical emergency standby power is available for a maximum of 500 hours per year at a maximum average load factor of 70%. The load should be variable and there is no overload (operation above nameplate) available for a standby rated product.

Limited Time Running Power (LTP)

Capable of supplying power to a load for a maximum of 500 hours per year. Typical operation is a varying load up to the full LTP nameplate rating of the engine. There is no overload capability available with a LTP rated engine. Additional operational hours may be available after an application review. Please consult the factory.

Prime Rated Power and Continuous Operating Power

Capable of supplying power to a variable load for an unlimited number of hours per year. Typical operation is a varying load with an average maximum load factor of 70% of the power rating. A 10% overload rating is available for a maximum of one (1) hour in every twelve (12) hours and will not exceed 25 total hours per year.

All Power Solutions International ratings are in accordance with ISO 3046 and ISO 8528. Ratings are based on standard fuel as defined by PSI Energy Technical Standard 56100019 – PSI Energy Fuel Standard.

CONVERSIONS

POWER

$$1 \text{ kW} = 1.36 \text{ metric Hp}$$

$$1 \text{ kW} = 1.341 \text{ bHp}$$

$$1 \text{ bHp} = 1.014 \text{ metric Hp}$$

TORQUE

$$1 \text{ Nm} = 0.102 \text{ mkg}$$

$$1 \text{ Nm} = 0.74 \text{ lb-ft}$$

$$\text{Nm} = \text{kW} * 9549/\text{rpm}$$

GAS ENGINES



- **QUALIFIED:** All of our engines are U.S. EPA factory certified
- **ACCESSIBLE:** Gas is one of the most accessible fuel sources
- **RELIABLE:** Pipelines are air and watertight, eliminating the risk of fuel contamination
- **ECONOMICAL:** The low cost of gas fuel can reduce your total operating expenses

kWe values are based on standard assumptions for mechanical and electrical losses. Ratings and performance are subject to site conditions and PSI application and ratings guidelines.

50Hz ENGINES 1500RPM

NATURAL GAS (NG)

PROPANE (LP)

| Engine Model | Displacement | Application | kWe | kWm | bHp | kWe | kWm | bHp |
|---------------|--------------|-------------|-----|-----|------|-----|-----|-----|
| PSI 2.4L | 2.4 | Standby | 20 | 26 | 35 | 22 | 29 | 39 |
| PSI 4.3L | 4.3 | Prime | 35 | 43 | 58 | 35 | 45 | 61 |
| PSI 4.3L | 4.3 | Standby | 40 | 48 | 64 | 40 | 51 | 68 |
| PSI 4.5L | 4.5 | Prime | 35 | 44 | 60 | 36 | 46 | 62 |
| PSI 4.5L | 4.5 | Standby | 41 | 45 | 59 | 43 | 47 | 60 |
| PSI 5.7L | 5.7 | Prime | 50 | 58 | 78 | 50 | 63 | 84 |
| PSI 5.7L | 5.7 | Standby | 55 | 65 | 87 | 60 | 70 | 94 |
| PSI 5.7L T | 5.7 | Standby | 65 | 75 | 101 | - | - | - |
| PSI 5.7L TCAC | 5.7 | Standby | 85 | 100 | 134 | 80 | 93 | 124 |
| PSI 6.7L | 6.7 | Prime | 55 | 66 | 88 | 60 | 72 | 96 |
| PSI 6.7L | 6.7 | Standby | 58 | 66 | 91 | 64 | 72 | 97 |
| PSI 6.7L T | 6.7 | Prime | 90 | 106 | 142 | 85 | 100 | 134 |
| PSI 6.7L T | 6.7 | Standby | 100 | 120 | 161 | 85 | 100 | 134 |
| PSI 8.1L | 8.1 | Prime | 55 | 67 | 90 | 55 | 67 | 90 |
| PSI 8.1L | 8.1 | Standby | 60 | 74 | 99 | 65 | 74 | 99 |
| PSI 8.1L T | 8.1 | Prime | 110 | 131 | 175 | 80 | 92 | 123 |
| PSI 8.1L T | 8.1 | Standby | 125 | 145 | 194 | 90 | 102 | 137 |
| PSI 8.8L | 8.8 | Prime | 75 | 91 | 122 | 85 | 103 | 139 |
| PSI 8.8L | 8.8 | Standby | 85 | 101 | 135 | 100 | 115 | 154 |
| PSI 8.8L T | 8.8 | Standby | 100 | 122 | 164 | - | - | - |
| PSI 8.8L TCAC | 8.8 | Standby | 125 | 162 | 217 | 110 | 143 | 192 |
| PSI 10L | 9.7 | Prime | 85 | 100 | 137 | 94 | 110 | 149 |
| PSI 10L | 9.7 | Standby | 85 | 100 | 137 | 94 | 110 | 149 |
| PSI 10L T | 9.7 | Prime | 180 | 200 | 284 | 135 | 160 | 217 |
| PSI 10L T | 9.7 | Standby | 200 | 230 | 284 | 135 | 160 | 217 |
| PSI 11L | 11.1 | Prime | 150 | 180 | 241 | 100 | 121 | 162 |
| PSI 11L | 11.1 | Standby | 175 | 200 | 268 | 115 | 134 | 180 |
| PSI 13L | 12.5 | Prime | 205 | 230 | 314 | 130 | 150 | 202 |
| PSI 13L | 12.5 | Standby | 223 | 250 | 314 | 130 | 150 | 202 |
| PSI 13L | 12.5 | Standby HO | 250 | 300 | 402 | 175 | 204 | 274 |
| PSI 14L | 14.6 | Prime | 210 | 248 | 332 | 130 | 154 | 206 |
| PSI 14L | 14.6 | Standby | 240 | 275 | 369 | 150 | 171 | 229 |
| PSI 17L | 16.7 | Prime | 275 | 320 | - | - | - | - |
| PSI 17L | 16.7 | Standby | 275 | 320 | - | - | - | - |
| PSI 18L | 18.3 | Standby | 270 | 320 | 429 | 200 | 247 | 331 |
| PSI 20L | 19.6 | Prime | 365 | 414 | 555 | 225 | 257 | 345 |
| PSI 20L | 19.6 | LTP | 365 | 414 | 555 | 225 | 257 | 345 |
| PSI 20L | 19.6 | Standby | 400 | 460 | 617 | 250 | 286 | 383 |
| PSI 22L | 21.9 | Prime | 280 | 340 | 456 | 210 | 248 | 333 |
| PSI 22L | 21.9 | Standby | 320 | 378 | 507 | 220 | 276 | 370 |
| PSI 32L | 31.8 | Prime | 450 | 510 | 637 | 300 | 344 | 461 |
| PSI 32L | 31.8 | LTP | 500 | 570 | 738 | 325 | 385 | 516 |
| PSI 32L | 31.8 | Standby | 525 | 600 | 805 | 350 | 405 | 543 |
| PSI 40L | 39.2 | Prime | 675 | 666 | 893 | 375 | 438 | 587 |
| PSI 40L | 39.2 | LTP | 650 | 740 | 992 | 425 | 487 | 653 |
| PSI 40L | 39.2 | Standby | 650 | 740 | 992 | 425 | 487 | 653 |
| PSI 53L | 52.8 | Prime | 775 | 888 | 1191 | 575 | 670 | 898 |
| PSI 53L | 52.8 | LTP | 850 | 987 | 1324 | 650 | 744 | 998 |
| PSI 53L | 52.8 | Standby | 850 | 987 | 1324 | 650 | 744 | 998 |

60Hz ENGINES 1800RPM

NATURAL GAS (NG)
PROPANE (LP)

| Engine Model | Displacement | Application | kWe | kWm | bHp | kWe | kWm | bHp |
|---------------|--------------|-------------|------|------|------|-----|-----|------|
| PSI 2.4L | 2.4 | Standby | 25 | 32 | 43 | 30 | 35 | 47 |
| PSI 2.4L T | 2.4 | Standby | 40 | 50 | 68 | 40 | 51 | 68 |
| PSI 4.3L | 4.3 | Prime | 40 | 52 | 70 | 45 | 55 | 74 |
| PSI 4.3L | 4.3 | Standby | 50 | 58 | 78 | 50 | 61 | 82 |
| PSI 4.5L | 4.5 | Prime | 40 | 50 | 67 | 40 | 50 | 67 |
| PSI 4.5L | 4.5 | Standby | 45 | 50 | 67 | 45 | 50 | 67 |
| PSI 5.7L | 5.7 | Prime | 55 | 70 | 94 | 60 | 76 | 102 |
| PSI 5.7L | 5.7 | Standby | 60 | 78 | 105 | 70 | 84 | 113 |
| PSI 5.7L T | 5.7 | Standby | 80 | 97 | 129 | - | - | - |
| PSI 5.7L TCAC | 5.7 | Standby | 100 | 122 | 164 | 90 | 111 | 149 |
| PSI 6.7L | 6.7 | Prime | 70 | 80 | 107 | 70 | 83 | 111 |
| PSI 6.7L | 6.7 | Standby | 70 | 80 | 107 | 77 | 88 | 118 |
| PSI 6.7L T | 6.7 | Prime | 100 | 120 | 160 | 85 | 99 | 132 |
| PSI 6.7L T | 6.7 | Standby | 125 | 145 | 194 | 85 | 99 | 132 |
| PSI 8.1L | 8.1 | Prime | 75 | 88 | 118 | 75 | 88 | 118 |
| PSI 8.1L | 8.1 | Standby | 85 | 100 | 134 | 80 | 100 | 134 |
| PSI 8.1L T | 8.1 | Prime | 125 | 150 | 201 | 95 | 111 | 148 |
| PSI 8.1L T | 8.1 | Standby | 155 | 176 | 236 | 110 | 130 | 174 |
| PSI 8.8L | 8.8 | Prime | 80 | 109 | 146 | 100 | 124 | 166 |
| PSI 8.8L | 8.8 | Standby | 100 | 121 | 162 | 115 | 138 | 185 |
| PSI 8.8L T | 8.8 | Standby | 125 | 147 | 197 | - | - | - |
| PSI 8.8L TCAC | 8.8 | Standby | 150 | 195 | 261 | 130 | 172 | 230 |
| PSI 8.8L TCAC | 8.8 | Standby H0 | 200 | 232 | 268 | - | - | - |
| PSI 10L | 9.7 | Prime | 100 | 118 | 158 | 110 | 130 | 174 |
| PSI 10L | 9.7 | Standby | 100 | 118 | 158 | 110 | 130 | 174 |
| PSI 10L T | 9.7 | Prime | 170 | 200 | 268 | 140 | 168 | 225 |
| PSI 10L T | 9.7 | Standby | 204 | 236 | 268 | 140 | 168 | 225 |
| PSI 11L | 11.1 | Prime | 175 | 200 | 268 | 110 | 132 | 177 |
| PSI 11L | 11.1 | Standby | 200 | 235 | 315 | 135 | 155 | 208 |
| PSI 13L | 12.5 | Prime | 207 | 240 | 322 | 150 | 180 | 241 |
| PSI 13L | 12.5 | Standby | 262 | 299 | 322 | 150 | 180 | 241 |
| PSI 13L | 12.5 | Standby H0 | 300 | 350 | 469 | 150 | 179 | 240 |
| PSI 14L | 14.6 | Prime | 250 | 291 | 390 | 175 | 202 | 271 |
| PSI 14L | 14.6 | Standby | 300 | 342 | 459 | 200 | 238 | 319 |
| PSI 14L | 14.6 | Standby H0 | 350 | 400 | 536 | - | - | - |
| PSI 17L | 16.7 | Prime | 350 | 420 | 550 | - | - | - |
| PSI 17L | 16.7 | Standby | 400 | 460 | 550 | - | - | - |
| PSI 18L | 18.3 | Standby | 350 | 422 | 566 | 250 | 297 | 398 |
| PSI 20L | 19.6 | Prime | 400 | 450 | 603 | 275 | 306 | 410 |
| PSI 20L | 19.6 | LTP | 400 | 450 | 603 | 275 | 306 | 410 |
| PSI 20L | 19.6 | Standby | 500 | 570 | 764 | 300 | 340 | 456 |
| PSI 22L | 21.9 | Prime | 375 | 434 | 581 | 250 | 299 | 401 |
| PSI 22L | 21.9 | Standby | 450 | 510 | 684 | 300 | 352 | 472 |
| PSI 22L | 21.9 | Standby H0 | 500 | 570 | 764 | - | - | - |
| PSI 32L | 31.8 | Prime | 525 | 600 | 805 | 350 | 403 | 540 |
| PSI 32L | 31.8 | LTP | 600 | 684 | 918 | 400 | 451 | 605 |
| PSI 32L | 31.8 | Standby | 650 | 720 | 966 | 425 | 475 | 637 |
| PSI 40L | 39.2 | Prime | 725 | 828 | 1110 | 450 | 526 | 705 |
| PSI 40L | 39.2 | LTP | 800 | 920 | 1234 | 500 | 584 | 783 |
| PSI 40L | 39.2 | Standby | 800 | 920 | 1234 | 500 | 584 | 783 |
| PSI 53L | 52.8 | Prime | 925 | 1067 | 1431 | 700 | 803 | 1077 |
| PSI 53L | 52.8 | LTP | 1050 | 1185 | 1589 | 775 | 892 | 1196 |
| PSI 53L | 52.8 | Standby | 1050 | 1185 | 1589 | 775 | 892 | 1196 |
| PSI 53L | 52.8 | Standby H0 | 1250 | 1436 | 1924 | - | - | - |

2.4L

| | |
|-----------------------|---|
| Cylinders | I-4 |
| Induction System | Naturally Aspirated |
| Combustion System | Spark-Ignited |
| Cooling System | Water-Cooled |
| Displacement | 143 cid (2,351 cc) |
| Compression Ratio | 9.5:1 |
| Bore & Stroke | 3.40 in x 3.93 in (86.5 mm x 100 mm) |
| Direction of Rotation | Counter-Clockwise Viewed on Flywheel |
| Dry Weight | 260 lbs (118 kg) |



50Hz (1500RPM)

| Application | Fuel | kWe | kWm | bHp |
|-------------|------|-----|-----|-----|
| Standby | NG | 20 | 26 | 35 |
| Standby | LP | 22 | 29 | 39 |

60Hz (1800RPM)

| Application | Fuel | kWe | kWm | bHp |
|-------------|------|-----|-----|-----|
| Standby | NG | 25 | 32 | 43 |
| Standby | LP | 30 | 35 | 47 |

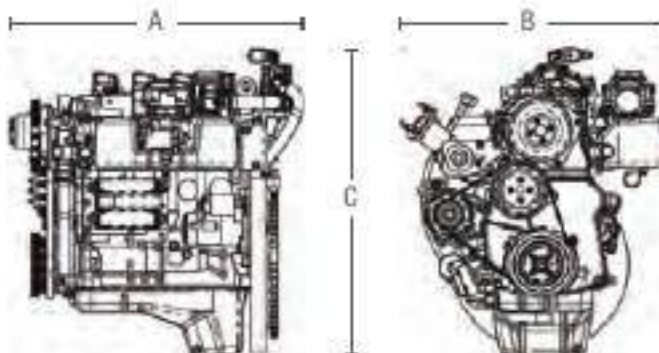

PRODUCT DIMENSIONS

- A – 24.8 in (629 mm)
- B – 24.6 in (626 mm)
- C – 29.2 in (742 mm)

2.4L T



| | |
|-----------------------|---|
| Cylinders | I-4 |
| Induction System | Turbocharged & Air-to-Air Charge Cooled |
| Combustion System | Spark-Ignited |
| Cooling System | Water-Cooled |
| Displacement | 143 cid (2,351 cc) |
| Compression Ratio | 9.5:1 |
| Bore & Stroke | 3.40 in x 3.93 in (86.5 mm x 100 mm) |
| Direction of Rotation | Counter-Clockwise Viewed on Flywheel |
| Dry Weight | 308 lbs (140 kg) |

50Hz (1500RPM)

| Application | Fuel | kWe | kWm | bHp |
|-------------|------|-----|-----|-----|
| Standby | NG | 24 | 29 | 39 |
| Standby | LP | 25 | 31 | 41 |

60Hz (1800RPM)

| Application | Fuel | kWe | kWm | bHp |
|-------------|------|-----|-----|-----|
| Standby | NG | 30 | 35 | 47 |
| Standby | LP | 32 | 38 | 51 |

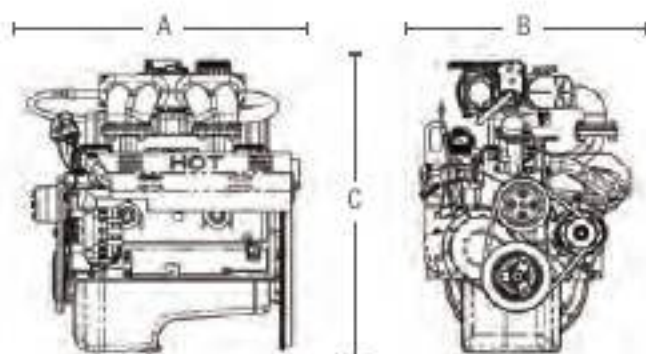

PRODUCT DIMENSIONS

- A – 25.3 in (644 mm)
- B – 18.0 in (457 mm)
- C – 24.5 in (624 mm)

4.3L

| | |
|-----------------------|---|
| Cylinders | V-6 |
| Induction System | Naturally Aspirated |
| Combustion System | Spark-Ignited |
| Cooling System | Water-Cooled |
| Displacement | 262 cid (4,294 cc) |
| Compression Ratio | 9.8:1 |
| Bore & Stroke | 4.00 in x 3.48 in (101.6 mm x 88.4 mm) |
| Direction of Rotation | Counter-Clockwise Viewed on Flywheel |
| Dry Weight | 430 lbs (195 kg) |



50Hz (1500RPM)

| Application | Fuel | kWe | kWm | bHp |
|-------------|------|-----|-----|-----|
| Standby | NG | 40 | 48 | 64 |
| Standby | LP | 40 | 51 | 68 |
| Prime | NG | 35 | 43 | 58 |
| Prime | LP | 35 | 45 | 61 |

60Hz (1800RPM)

| Application | Fuel | kWe | kWm | bHp |
|-------------|------|-----|-----|-----|
| Standby | NG | 50 | 58 | 78 |
| Standby | LP | 50 | 61 | 82 |
| Prime | NG | 40 | 52 | 70 |
| Prime | LP | 45 | 55 | 74 |

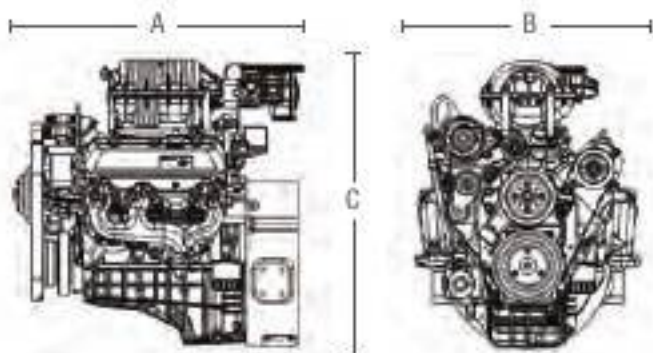

PRODUCT DIMENSIONS

A – 31.1 in (790 mm)

B – 24.1 in (613 mm)

C – 30.9 in (785 mm)

4.5L



| | |
|-----------------------|---|
| Cylinders | I-4 |
| Induction System | Naturally Aspirated |
| Combustion System | Spark-Ignited |
| Cooling System | Water-Cooled |
| Displacement | 274 cid (4,500 cc) |
| Compression Ratio | 9.75:1 |
| Bore & Stroke | 4.13 in x 5.12 in (105 mm x 130 mm) |
| Direction of Rotation | Counter-Clockwise Viewed on Flywheel |
| Dry Weight | 1,102 lbs (500 kg) |

50Hz (1500RPM)

| Application | Fuel | kWe | kWm | bHp |
|-------------|------|-----|-----|-----|
| Standby | NG | 41 | 45 | 59 |
| Standby | LP | 43 | 47 | 60 |
| Prime | NG | 35 | 44 | 60 |
| Prime | LP | 36 | 46 | 62 |

60Hz (1800RPM)

| Application | Fuel | kWe | kWm | bHp |
|-------------|------|-----|-----|-----|
| Standby | NG | 45 | 50 | 67 |
| Standby | LP | 45 | 50 | 67 |
| Prime | NG | 40 | 50 | 67 |
| Prime | LP | 40 | 50 | 67 |

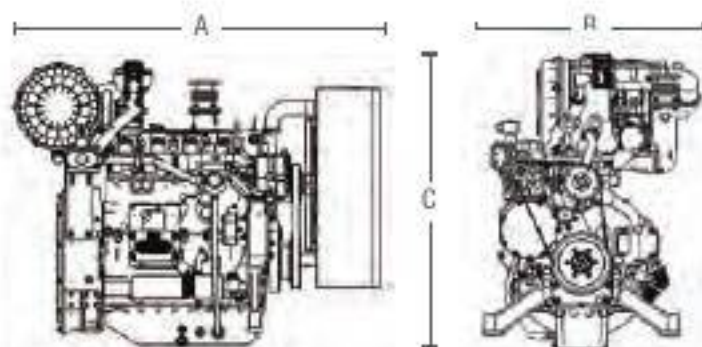

PRODUCT DIMENSIONS

- A – 56.1 in (1,426 mm)
- B – 31.9 in (811 mm)
- C – 43.2 in (1,098 mm)

5.7L

| | |
|-----------------------|---|
| Cylinders | V-8 |
| Induction System | Naturally Aspirated |
| Combustion System | Spark-Ignited |
| Cooling System | Water-Cooled |
| Displacement | 350 cid (5,737 cc) |
| Compression Ratio | 9.4:1 |
| Bore & Stroke | 4.00 in x 3.48 in (101.6 mm x 88.4 mm) |
| Direction of Rotation | Counter-Clockwise Viewed on Flywheel |
| Dry Weight | 432 lbs (196 kg) |



50Hz (1500RPM)

| Application | Fuel | kWe | kWm | bHp |
|-------------|------|-----|-----|-----|
| Standby | NG | 55 | 65 | 87 |
| Standby | LP | 60 | 70 | 94 |
| Prime | NG | 50 | 58 | 78 |
| Prime | LP | 50 | 63 | 84 |

60Hz (1800RPM)

| Application | Fuel | kWe | kWm | bHp |
|-------------|------|-----|-----|-----|
| Standby | NG | 60 | 78 | 105 |
| Standby | LP | 70 | 84 | 113 |
| Prime | NG | 55 | 70 | 94 |
| Prime | LP | 60 | 76 | 102 |

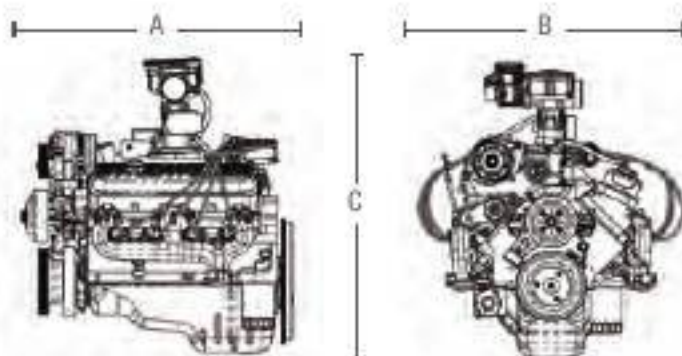

PRODUCT DIMENSIONS

A – 30.4 in (771 mm)

B – 23.7 in (603 mm)

C – 33.7 in (856 mm)

5.7L T/TCAC



| | |
|-----------------------|---|
| Cylinders | V-8 |
| Induction System | Turbocharged & Air-to-Air Charge Cooled |
| Combustion System | Spark-Ignited |
| Cooling System | Water-Cooled |
| Displacement | 350 cid (5,737 cc) |
| Compression Ratio | 9.4:1 |
| Bore & Stroke | 4.00 in x 3.48 in (101.6 mm x 88.4 mm) |
| Direction of Rotation | Counter-Clockwise Viewed on Flywheel |
| Dry Weight | 432 lbs (196 kg) |

50Hz (1500RPM)

| Application | Fuel | kWe | kWm | bHp |
|----------------|------|-----|-----|-----|
| Standby - T | NG | 65 | 75 | 101 |
| Standby - TCAC | NG | 85 | 100 | 134 |
| Standby - TCAC | LP | 80 | 93 | 124 |

60Hz (1800RPM)

| Application | Fuel | kWe | kWm | bHp |
|----------------|------|-----|-----|-----|
| Standby - T | NG | 80 | 97 | 129 |
| Standby - TCAC | NG | 100 | 122 | 164 |
| Standby - TCAC | LP | 90 | 111 | 149 |

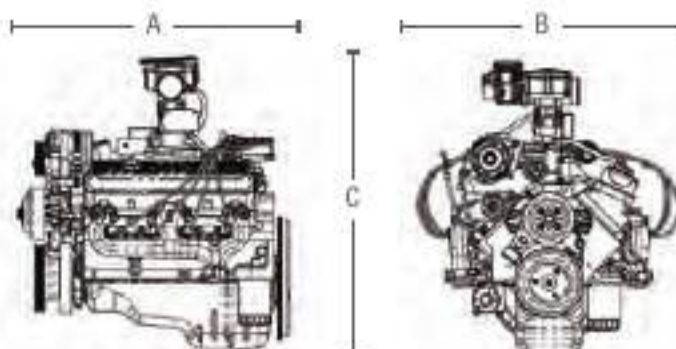

PRODUCT DIMENSIONS

- A – 30.4 in (771 mm)
- B – 23.7 in (603 mm)
- C – 33.7 in (856 mm)

6.7L

| | |
|-----------------------|---|
| Cylinders | I-6 |
| Induction System | Naturally Aspirated |
| Combustion System | Spark-Ignited |
| Cooling System | Water-Cooled |
| Displacement | 412 cid (6,750 cc) |
| Compression Ratio | 9.8:1 |
| Bore & Stroke | 4.13 in x 5.12 in (105 mm x 130 mm) |
| Direction of Rotation | Counter-Clockwise Viewed on Flywheel |
| Dry Weight | 1,499 lbs (680 kg) |



50Hz (1500RPM)

| Application | Fuel | kWe | kWm | bHp |
|-------------|------|-----|-----|-----|
| Standby | NG | 58 | 66 | 91 |
| Standby | LP | 64 | 72 | 97 |
| Prime | NG | 55 | 66 | 88 |
| Prime | LP | 60 | 72 | 96 |

60Hz (1800RPM)

| Application | Fuel | kWe | kWm | bHp |
|-------------|------|-----|-----|-----|
| Standby | NG | 70 | 80 | 107 |
| Standby | LP | 77 | 88 | 118 |
| Prime | NG | 70 | 80 | 107 |
| Prime | LP | 70 | 83 | 111 |

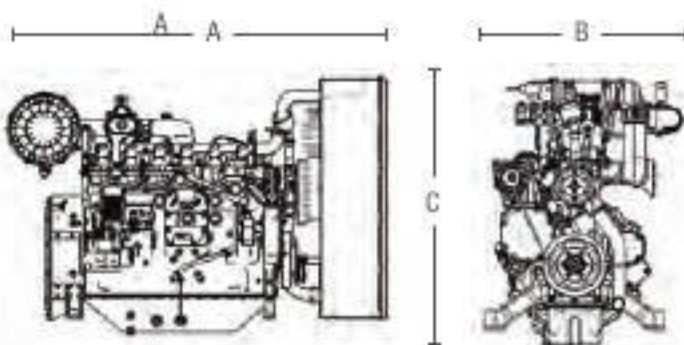

PRODUCT DIMENSIONS

A – 68.0 in (1,728 mm)

B – 33.1 in (840 mm)

C – 45.7 in (1,160 mm)

6.7L T



| | |
|-----------------------|---|
| Cylinders | I-6 |
| Induction System | Turbocharged & Air-to-Air Charge Cooled |
| Combustion System | Spark-Ignited |
| Cooling System | Water-Cooled |
| Displacement | 412 cid (6,750 cc) |
| Compression Ratio | 9.8:1 |
| Bore & Stroke | 4.13 in x 5.12 in (105 mm x 130 mm) |
| Direction of Rotation | Counter-Clockwise Viewed on Flywheel |
| Dry Weight | 1,499 lbs (680 kg) |

50Hz (1500RPM)

| Application | Fuel | kWe | kWm | bHp |
|-------------|------|-----|-----|-----|
| Standby | NG | 100 | 120 | 161 |
| Standby | LP | 85 | 100 | 134 |
| Prime | NG | 90 | 106 | 142 |
| Prime | LP | 85 | 100 | 134 |

60Hz (1800RPM)

| Application | Fuel | kWe | kWm | bHp |
|-------------|------|-----|-----|-----|
| Standby | NG | 125 | 145 | 194 |
| Standby | LP | 85 | 99 | 132 |
| Prime | NG | 100 | 120 | 160 |
| Prime | LP | 85 | 99 | 132 |

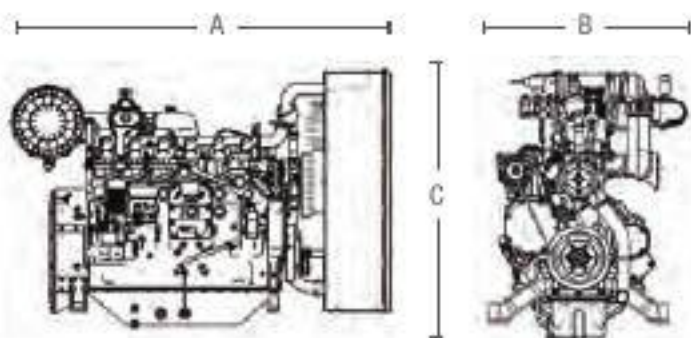

PRODUCT DIMENSIONS

- A – 66.1 in (1,679 mm)
- B – 32.6 in (828 mm)
- C – 45.9 in (1,166 mm)

8.1L

| | |
|-----------------------|---|
| Cylinders | I-6 |
| Induction System | Naturally Aspirated |
| Combustion System | Spark-Ignited |
| Cooling System | Water-Cooled |
| Displacement | 492 cid (8,064 cc) |
| Compression Ratio | 10.5:1 |
| Bore & Stroke | 4.37 in x 5.47 in (111 mm x 139 mm) |
| Direction of Rotation | Counter-Clockwise Viewed on Flywheel |
| Dry Weight | 2,200 lbs (998 kg) |

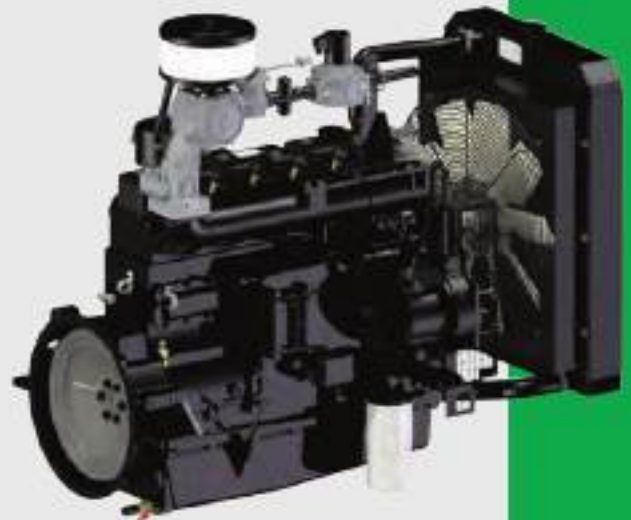

50Hz (1500RPM)

| Application | Fuel | kWe | kWm | bHp |
|-------------|------|-----|-----|-----|
| Standby | NG | 60 | 74 | 99 |
| Standby | LP | 65 | 74 | 99 |
| Prime | NG | 55 | 67 | 90 |
| Prime | LP | 55 | 67 | 90 |

60Hz (1800RPM)

| Application | Fuel | kWe | kWm | bHp |
|-------------|------|-----|-----|-----|
| Standby | NG | 85 | 100 | 134 |
| Standby | LP | 80 | 100 | 134 |
| Prime | NG | 75 | 88 | 118 |
| Prime | LP | 75 | 88 | 118 |

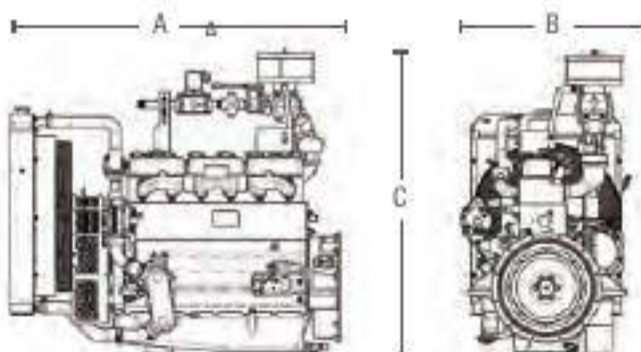

PRODUCT DIMENSIONS

A – 74.5 in (1,893 mm)

B – 43.5 in (1,105 mm)

C – 51.9 in (1,319 mm)

8.1L T



| | |
|-----------------------|---|
| Cylinders | I-6 |
| Induction System | Turbocharged & Air-to-Air Charge Cooled |
| Combustion System | Spark-Ignited |
| Cooling System | Water-Cooled |
| Displacement | 492 cid (8,064 cc) |
| Compression Ratio | 10.5:1 |
| Bore & Stroke | 4.37 in x 5.47 in (111 mm x 139 mm) |
| Direction of Rotation | Counter-Clockwise Viewed on Flywheel |
| Dry Weight | 2,200 lbs (998 kg) |

50Hz (1500RPM)

| Application | Fuel | kWe | kWm | bHp |
|-------------|------|-----|-----|-----|
| Standby | NG | 125 | 145 | 194 |
| Standby | LP | 90 | 102 | 137 |
| Prime | NG | 110 | 131 | 175 |
| Prime | LP | 80 | 92 | 123 |

60Hz (1800RPM)

| Application | Fuel | kWe | kWm | bHp |
|-------------|------|-----|-----|-----|
| Standby | NG | 155 | 176 | 236 |
| Standby | LP | 110 | 130 | 174 |
| Prime | NG | 125 | 150 | 201 |
| Prime | LP | 95 | 111 | 148 |

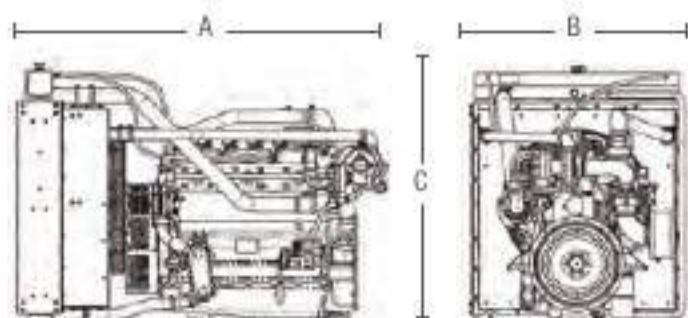

PRODUCT DIMENSIONS

- A – 74.5 in (1,893 mm)
- B – 43.5 in (1,105 mm)
- C – 51.9 in (1,319 mm)

8.8L T/TCAC

| | |
|-----------------------|--|
| Cylinders | V-8 |
| Induction System | Naturally Aspirated |
| Combustion System | Spark-Ignited |
| Cooling System | Water-Cooled |
| Displacement | 535 cid (8,800 cc) |
| Compression Ratio | 10:1 |
| Bore & Stroke | 4.35 in x 4.50 in (110.5 mm x 114.3 mm) |
| Direction of Rotation | Counter-Clockwise Viewed on Flywheel |
| Dry Weight | 707 lbs (321 kg) |



50Hz (1500RPM)

| Application | Fuel | kWe | kWm | bHp |
|-------------|------|-----|-----|-----|
| Standby | NG | 85 | 101 | 135 |
| Standby | LP | 100 | 115 | 154 |
| Prime | NG | 75 | 91 | 122 |
| Prime | LP | 85 | 103 | 139 |

60Hz (1800RPM)

| Application | Fuel | kWe | kWm | bHp |
|-------------|------|-----|-----|-----|
| Standby | NG | 100 | 121 | 162 |
| Standby | LP | 115 | 138 | 185 |
| Prime | NG | 80 | 109 | 146 |
| Prime | LP | 100 | 124 | 166 |

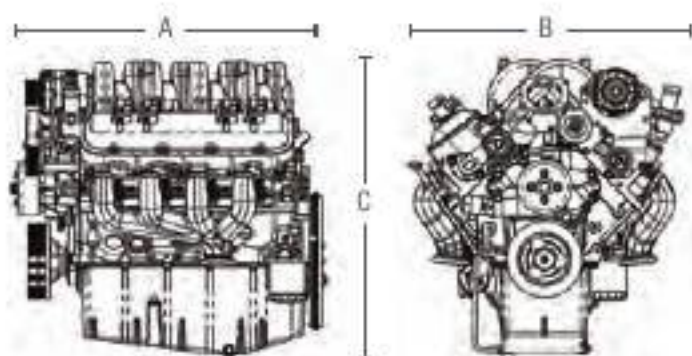

PRODUCT DIMENSIONS

A – 31.9 in (808 mm)

B – 27.5 in (697 mm)

C – 30.1 in (765 mm)

8.8L TCAC HO



| | |
|-----------------------|---|
| Cylinders | V-8 |
| Induction System | Turbocharged & Air-to-Air Charge Cooled |
| Combustion System | Spark-Ignited |
| Cooling System | Water-Cooled |
| Displacement | 535 cid (8,800 cc) |
| Compression Ratio | 10:1 |
| Bore & Stroke | 5.91 in x 7.28 in (150 mm x 185 mm) |
| Direction of Rotation | Counter-Clockwise Viewed on Flywheel |
| Dry Weight | 1218 lbs (552 kg) |

50Hz (1500RPM)

| Application | Fuel | kWe | kWm | bHp |
|----------------|------|-----|-----|-----|
| Standby - T | NG | 100 | 122 | 164 |
| Standby - TCAC | NG | 125 | 162 | 217 |
| Standby - TCAC | LP | 110 | 143 | 192 |

60Hz (1800RPM)

| Application | Fuel | kWe | kWm | bHp |
|-------------------|------|-----|-----|-----|
| Standby - T | NG | 125 | 147 | 197 |
| Standby - TCAC | NG | 150 | 195 | 261 |
| Standby - TCAC HO | NG | 200 | 232 | 268 |
| Standby - TCAC | LP | 130 | 172 | 230 |

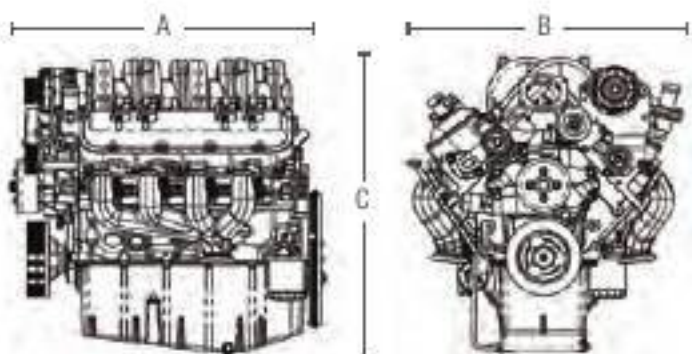

PRODUCT DIMENSIONS

- A – 31.9 in (808 mm)
- B – 27.5 in (697 mm)
- C – 30.1 in (765 mm)

10L

| | |
|-----------------------|---|
| Cylinders | I-6 |
| Induction System | Naturally Aspirated |
| Combustion System | Spark-Ignited |
| Cooling System | Water-Cooled |
| Displacement | 593 cid (9,726 cc) |
| Compression Ratio | 9.75:1 |
| Bore & Stroke | 5.00 in x 5.10 in (126 mm x 130 mm) |
| Direction of Rotation | Counter-Clockwise Viewed on Flywheel |
| Dry Weight | 2,359 lbs (1070 kg) |



50Hz (1500RPM)

| Application | Fuel | kWe | kWm | bHp |
|-------------|------|-----|-----|-----|
| Standby | NG | 85 | 100 | 37 |
| Standby | LP | 94 | 110 | 149 |
| Prime | NG | 85 | 100 | 37 |
| Prime | LP | 94 | 110 | 149 |

60Hz (1800RPM)

| Application | Fuel | kWe | kWm | bHp |
|-------------|------|-----|-----|-----|
| Standby | NG | 100 | 118 | 158 |
| Standby | LP | 110 | 130 | 174 |
| Prime | NG | 100 | 118 | 158 |
| Prime | LP | 110 | 130 | 174 |

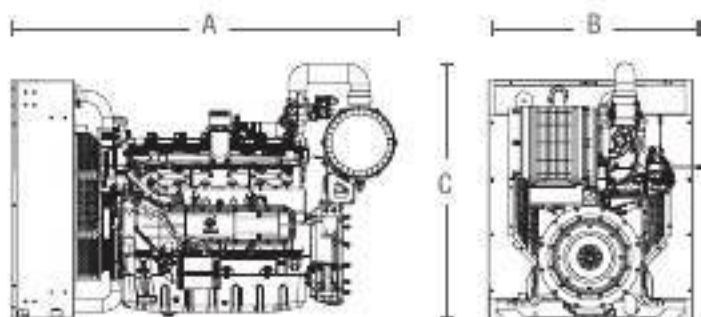

PRODUCT DIMENSIONS

- A – 83.5 in (2,122 mm)
- B – 43.3 in (1,100 mm)
- C – 55.0 in (1396 mm)

IOL T

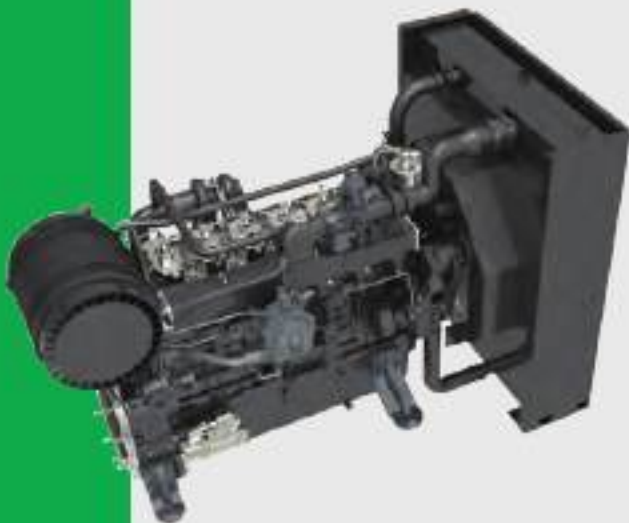

| | |
|-----------------------|---|
| Cylinders | I-6 |
| Induction System | Turbocharged & Air-to-Air Charge Cooled |
| Combustion System | Spark-Ignited |
| Cooling System | Water-Cooled |
| Displacement | 593 cid (9,726 cc) |
| Compression Ratio | 9.75:1 |
| Bore & Stroke | 5.00 in x 5.10 in (126 mm x 130 mm) |
| Direction of Rotation | Counter-Clockwise Viewed on Flywheel |
| Dry Weight | 2,601 lbs (1,180 kg) |

50Hz (1500RPM)

| Application | Fuel | kWe | kWm | bHp |
|-------------|------|-----|-----|-----|
| Standby | NG | 200 | 230 | 284 |
| Standby | LP | 135 | 160 | 217 |
| Prime | NG | 180 | 200 | 284 |
| Prime | LP | 135 | 160 | 217 |

60Hz (1800RPM)

| Application | Fuel | kWe | kWm | bHp |
|-------------|------|-----|-----|-----|
| Standby | NG | 204 | 236 | 268 |
| Standby | LP | 140 | 168 | 225 |
| Prime | NG | 170 | 200 | 268 |
| Prime | LP | 140 | 168 | 225 |

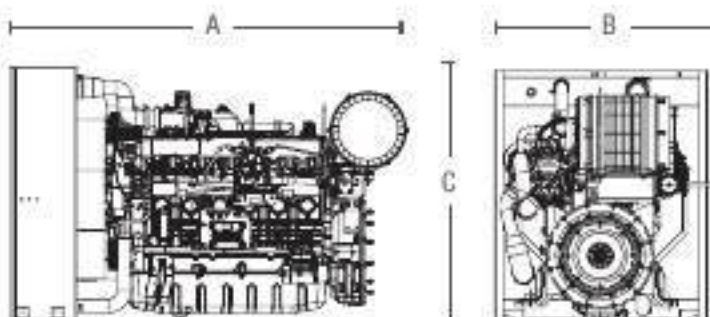

PRODUCT DIMENSIONS

- A – 80.9 in (2,055 mm)
- B – 43.3 in (1,100 mm)
- C – 50.9 in (1,294 mm)

11L

| | |
|-----------------------|---|
| Cylinders | I-6 |
| Induction System | Turbocharged & Air-to-Air Charge Cooled |
| Combustion System | Spark-Ignited |
| Cooling System | Water-Cooled |
| Displacement | 673 cid (11,051 cc) |
| Compression Ratio | 10.5:1 |
| Bore & Stroke | 4.84 in x 6.10 in (123 mm x 155 mm) |
| Direction of Rotation | Counter-Clockwise Viewed on Flywheel |
| Dry Weight | 2,600 lbs (1,179 kg) |



50Hz (1500RPM)

| Application | Fuel | kWe | kWm | bHp |
|-------------|------|-----|-----|-----|
| Standby | NG | 175 | 200 | 268 |
| Standby | LP | 115 | 134 | 180 |
| Prime | NG | 150 | 180 | 241 |
| Prime | LP | 100 | 121 | 162 |

60Hz (1800RPM)

| Application | Fuel | kWe | kWm | bHp |
|-------------|------|-----|-----|-----|
| Standby | NG | 200 | 235 | 315 |
| Standby | LP | 135 | 155 | 208 |
| Prime | NG | 175 | 200 | 268 |
| Prime | LP | 110 | 132 | 177 |

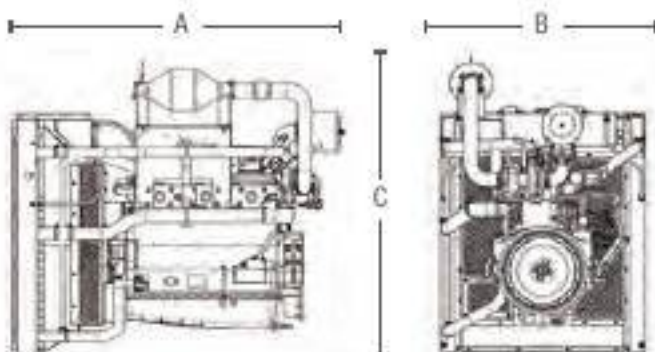

PRODUCT DIMENSIONS

- A – 70.8 in (1,798 mm)
- B – 50.0 in (1,270 mm)
- C – 59.5 in (1,512 mm)

13L



| | |
|-----------------------|---|
| Cylinders | I-6 |
| Induction System | Turbocharged & Air-to-Air Charge Cooled |
| Combustion System | Spark-Ignited |
| Cooling System | Water-Cooled |
| Displacement | 765 cid (12,500 cc) |
| Compression Ratio | 9.75:1 |
| Bore & Stroke | 5.00 in x 6.50 in (127 mm x 165 mm) |
| Direction of Rotation | Counter-Clockwise Viewed on Flywheel |
| Dry Weight | 3,018 lbs (1,370 kg) |

50Hz (1500RPM)

| Application | Fuel | kWe | kWm | bHp |
|-------------|------|-----|-----|-----|
| Standby HO | NG | 250 | 300 | 402 |
| Standby HO | LP | 175 | 204 | 274 |
| Standby | NG | 223 | 250 | 314 |
| Standby | LP | 130 | 150 | 202 |
| Prime | NG | 205 | 230 | 314 |
| Prime | LP | 130 | 150 | 202 |

60Hz (1800RPM)

| Application | Fuel | kWe | kWm | bHp |
|-------------|------|-----|-----|-----|
| Standby HO | NG | 300 | 350 | 469 |
| Standby HO | LP | 150 | 179 | 240 |
| Standby | NG | 262 | 299 | 322 |
| Standby | LP | 150 | 180 | 241 |
| Prime | NG | 207 | 240 | 322 |
| Prime | LP | 150 | 180 | 241 |

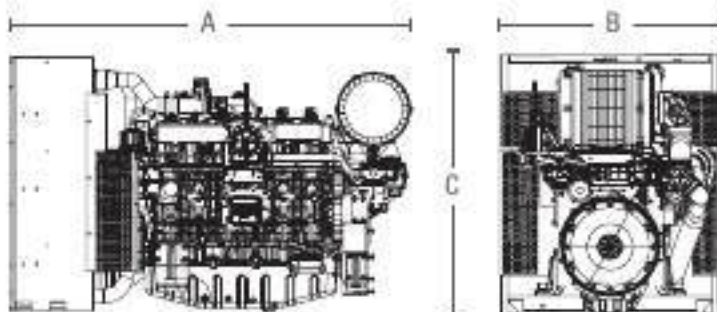

PRODUCT DIMENSIONS

A – 84.7 in (2,151 mm)

B – 44.6 in (1,133 mm)

C – 53.2 in (1,351 mm)

14L

| | |
|-----------------------|---|
| Cylinders | V-8 |
| Induction System | Turbocharged & Air-to-Air Charge Cooled |
| Combustion System | Spark-Ignited |
| Cooling System | Water-Cooled |
| Displacement | 892 cid (14,620 cc) |
| Compression Ratio | 10.5:1 |
| Bore & Stroke | 5.04 in x 5.59 in (128 mm x 142 mm) |
| Direction of Rotation | Counter-Clockwise Viewed on Flywheel |
| Dry Weight | 3,150 lbs (1,429 kg) |



50Hz (1500RPM)

| Application | Fuel | kWe | kWm | bHp |
|-------------|------|-----|-----|-----|
| Standby | NG | 240 | 275 | 369 |
| Standby | LP | 150 | 171 | 229 |
| Prime | NG | 210 | 248 | 332 |
| Prime | LP | 130 | 154 | 206 |

60Hz (1800RPM)

| Application | Fuel | kWe | kWm | bHp |
|-------------|------|-----|-----|-----|
| Standby HO | NG | 350 | 400 | 536 |
| Standby | NG | 300 | 342 | 459 |
| Standby | LP | 200 | 238 | 319 |
| Prime | NG | 250 | 291 | 390 |
| Prime | LP | 175 | 202 | 271 |

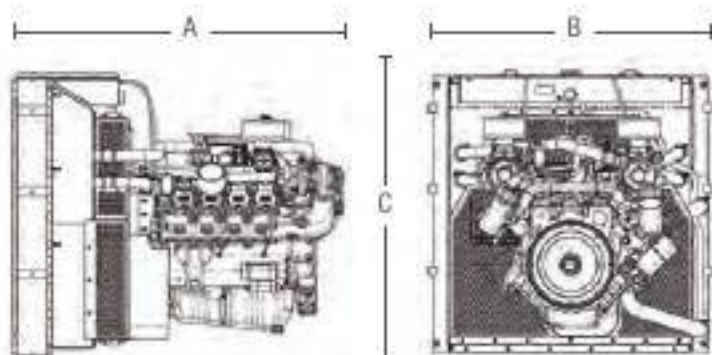

PRODUCT DIMENSIONS

- A – 75.5 in (1,918 mm)
- B – 65.0 in (1,651 mm)
- C – 83.6 in (2,124 mm)

17L



| | |
|-----------------------|---|
| Cylinders | V-8 |
| Induction System | Turbocharged & Air-to-Air Charge Cooled |
| Combustion System | Spark-Ignited |
| Cooling System | Water-Cooled |
| Displacement | 1020 cid (16,720 cc) |
| Compression Ratio | 10.5:1 |
| Bore & Stroke | 5.00 in x 6.50 in (127 mm x 165 mm) |
| Direction of Rotation | Counter-Clockwise Viewed on Flywheel |
| Dry Weight | 3,527 lbs (1,600 kg) |

50Hz (1500RPM)

| Application | Fuel | kWe | kWm | bHp |
|-------------|------|-----|-----|-----|
| Standby | NG | 275 | 320 | — |
| Prime | NG | 275 | 320 | — |

60Hz (1800RPM)

| Application | Fuel | kWe | kWm | bHp |
|-------------|------|-----|-----|-----|
| Standby | NG | 400 | 460 | 550 |
| Prime | NG | 350 | 420 | 550 |

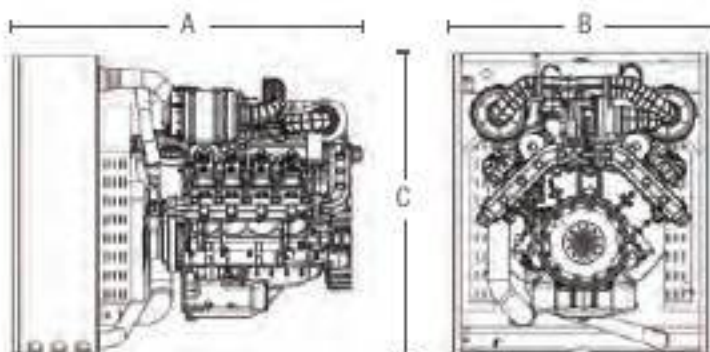

PRODUCT DIMENSIONS

A – 82.4 in (2094 mm)

B – 59.1 in (1500 mm)

C – 69.8 in (1772 mm)

18L

| | |
|-----------------------|---|
| Cylinders | V-10 |
| Induction System | Turbocharged & Air-to-Air Charge Cooled |
| Combustion System | Spark-Ignited |
| Cooling System | Water-Cooled |
| Displacement | 1,115 cid (18,275 cc) |
| Compression Ratio | 10.5:1 |
| Bore & Stroke | 5.04 in x 5.59 in (128 mm x 142 mm) |
| Direction of Rotation | Counter-Clockwise Viewed on Flywheel |
| Dry Weight | 3,400 lbs (1,542 kg) |



50Hz (1500RPM)

| Application | Fuel | kWe | kWm | bHp |
|-------------|------|-----|-----|-----|
| Standby | NG | 270 | 320 | 429 |
| Standby | LP | 200 | 247 | 331 |

60Hz (1800RPM)

| Application | Fuel | kWe | kWm | bHp |
|-------------|------|-----|-----|-----|
| Standby | NG | 350 | 422 | 566 |
| Standby | LP | 250 | 297 | 398 |

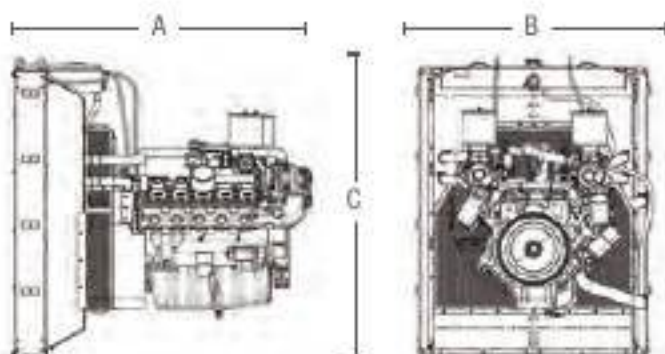

PRODUCT DIMENSIONS

A – 82.6 in (2,098 mm)

B – 65.0 in (1,651 mm)

C – 83.6 in (2,124 mm)

20L



| | |
|-----------------------|---|
| Cylinders | I-6 |
| Induction System | Turbocharged & Air-to-Air Charge Cooled |
| Combustion System | Spark-Ignited |
| Cooling System | Water-Cooled |
| Displacement | cid (19,600 cc) |
| Compression Ratio | 10.5:1 |
| Bore & Stroke | 5.90 in x 7.30 in (150 mm x 185 mm) |
| Direction of Rotation | Counter-Clockwise Viewed on Flywheel |
| Dry Weight | 4,648 lbs (2110 kg) |

50Hz (1500RPM)

| Application | Fuel | kWe | kWm | bHp |
|-------------|------|-----|-----|-----|
| Standby | NG | 400 | 460 | 617 |
| Standby | LP | 250 | 286 | 383 |
| LTP | NG | 365 | 414 | 555 |
| LTP | LP | 225 | 257 | 345 |
| Prime | NG | 365 | 414 | 555 |
| Prime | LP | 225 | 257 | 345 |

60Hz (1800RPM)

| Application | Fuel | kWe | kWm | bHp |
|-------------|------|-----|-----|-----|
| Standby | NG | 500 | 570 | 764 |
| Standby | LP | 300 | 340 | 456 |
| LTP | NG | 400 | 450 | 603 |
| LTP | LP | 275 | 306 | 410 |
| Prime | NG | 400 | 450 | 603 |
| Prime | LP | 275 | 306 | 410 |

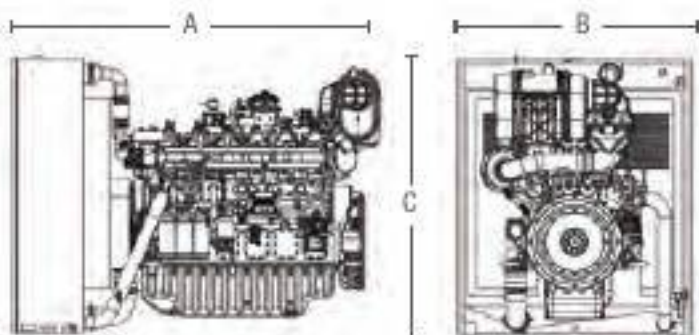

PRODUCT DIMENSIONS

- A – 99.8 in (2,536 mm)
- B – 62.7 in (1,592 mm)
- C – 74.8 in (1,900 mm)

22L

| | |
|-----------------------|---|
| Cylinders | V-12 |
| Induction System | Turbocharged & Air-to-Air Charge Cooled |
| Combustion System | Spark-Ignited |
| Cooling System | Water-Cooled |
| Displacement | 1,338 cid (21,561 cc) |
| Compression Ratio | 10.5:1 |
| Bore & Stroke | 5.04 in x 5.59 in (128 mm x 142 mm) |
| Direction of Rotation | Counter-Clockwise Viewed on Flywheel |
| Dry Weight | 3,638 lbs (1,650 kg) |



50Hz (1500RPM)

| Application | Fuel | kWe | kWm | bHp |
|-------------|------|-----|-----|-----|
| Standby | NG | 320 | 378 | 507 |
| Standby | LP | 220 | 276 | 370 |
| Prime | NG | 280 | 340 | 456 |
| Prime | LP | 210 | 248 | 333 |

60Hz (1800RPM)

| Application | Fuel | kWe | kWm | bHp |
|-------------|------|-----|-----|-----|
| Standby HO | NG | 500 | 570 | 764 |
| Standby | NG | 450 | 510 | 684 |
| Standby | LP | 300 | 352 | 472 |
| Prime | NG | 375 | 434 | 581 |
| Prime | LP | 250 | 299 | 401 |

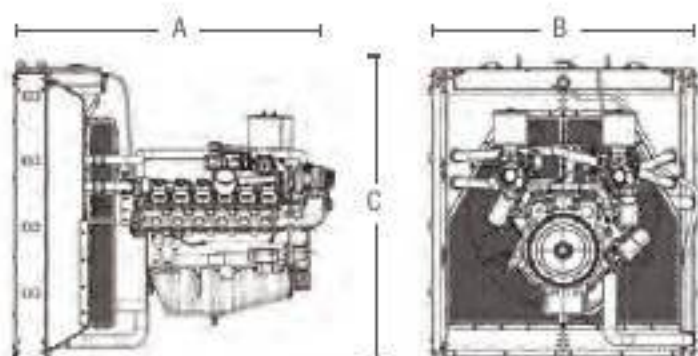

PRODUCT DIMENSIONS

A – 90.3 in (2,294 mm)

B – 75.3 in (1,914 mm)

C – 83.6 in (2,124 mm)

32L



| | |
|-----------------------|---|
| Cylinders | V-12 |
| Induction System | Turbocharged & Air-to-Air Charge Cooled |
| Combustion System | Spark-Ignited |
| Cooling System | Water-Cooled |
| Displacement | 1,941 cid (31,800 cc) |
| Compression Ratio | 10.5:1 |
| Bore & Stroke | 5.91 in x 5.91 in (150 mm x 150 mm) |
| Direction of Rotation | Counter-Clockwise Viewed on Flywheel |
| Dry Weight | 6887 lbs (3124 kg) |

50Hz (1500RPM)

| Application | Fuel | kWe | kWm | bHp |
|-------------|------|-----|-----|-----|
| Standby | NG | 525 | 600 | 805 |
| Standby | LP | 350 | 405 | 543 |
| LTP | NG | 500 | 570 | 738 |
| LTP | LP | 325 | 385 | 516 |
| Prime | NG | 450 | 510 | 637 |
| Prime | LP | 300 | 344 | 461 |

60Hz (1800RPM)

| Application | Fuel | kWe | kWm | bHp |
|-------------|------|-----|-----|-----|
| Standby | NG | 650 | 720 | 966 |
| Standby | LP | 425 | 475 | 637 |
| LTP | NG | 600 | 684 | 918 |
| LTP | LP | 400 | 451 | 605 |
| Prime | NG | 525 | 600 | 805 |
| Prime | LP | 350 | 403 | 540 |

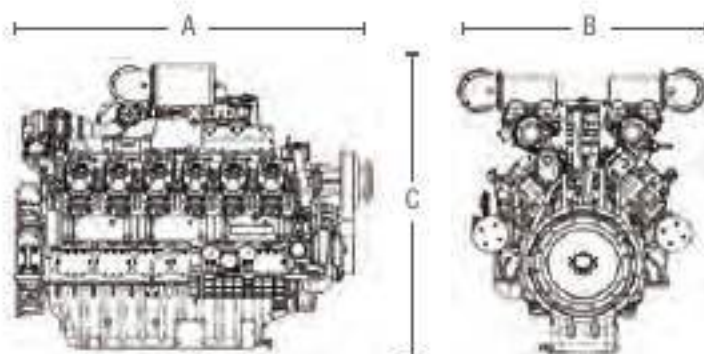

PRODUCT DIMENSIONS

- A – 84.0 in (2,134 mm)
- B – 58.0 in (1,473 mm)
- C – 66.9 in (1,699 mm)

40L

| | |
|-----------------------|---|
| Cylinders | V-12 |
| Induction System | Turbocharged & Air-to-Air Charge Cooled |
| Combustion System | Spark-Ignited |
| Cooling System | Water-Cooled |
| Displacement | 2,394 cid (39,230 cc) |
| Compression Ratio | 10.5:1 |
| Bore & Stroke | 5.91 in x 7.28 in (150 mm x 185 mm) |
| Direction of Rotation | Counter-Clockwise Viewed on Flywheel |
| Dry Weight | 7,474 lbs (3,390 kg) |



50Hz (1500RPM)

| Application | Fuel | kWe | kWm | bHp |
|-------------|------|-----|-----|-----|
| Standby | NG | 650 | 740 | 992 |
| Standby | LP | 425 | 487 | 653 |
| LTP | NG | 650 | 740 | 992 |
| LTP | LP | 425 | 487 | 653 |
| Prime | NG | 875 | 666 | 893 |
| Prime | LP | 375 | 438 | 587 |

60Hz (1800RPM)

| Application | Fuel | kWe | kWm | bHp |
|-------------|------|-----|-----|------|
| Standby | NG | 800 | 920 | 1234 |
| Standby | LP | 500 | 584 | 783 |
| LTP | NG | 800 | 920 | 1234 |
| LTP | LP | 500 | 584 | 783 |
| Prime | NG | 725 | 828 | 1110 |
| Prime | LP | 450 | 526 | 705 |

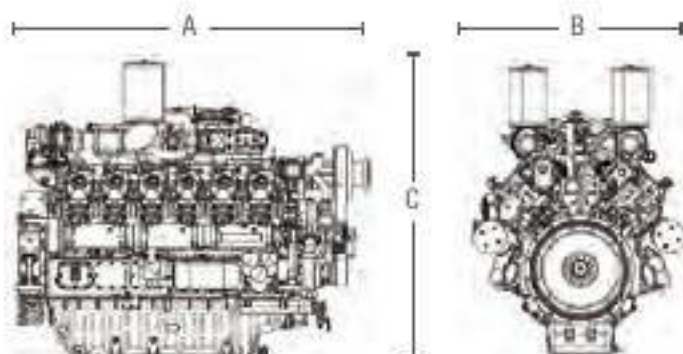

PRODUCT DIMENSIONS

- A – 87.2 in (2,215 mm)
- B – 54.2 in (1,377 mm)
- C – 73.3 in (1,862 mm)

53L



| | |
|-----------------------|---|
| Cylinders | V-16 |
| Induction System | Turbocharged & Air-to-Air Charge Cooled |
| Combustion System | Spark-Ignited |
| Cooling System | Water-Cooled |
| Displacement | 3,192 cid (52,308 cc) |
| Compression Ratio | 10.5:1 |
| Bore & Stroke | 5.91 in x 7.28 in (150 mm x 185 mm) |
| Direction of Rotation | Counter-Clockwise Viewed on Flywheel |
| Dry Weight | 12,125 lbs (5,500 kg) |

50Hz (1500RPM)

| Application | Fuel | kWe | kWm | bHp |
|-------------|------|-----|-----|------|
| Standby | NG | 850 | 987 | 1324 |
| Standby | LP | 650 | 744 | 998 |
| LTP | NG | 850 | 987 | 1324 |
| LTP | LP | 650 | 744 | 998 |
| Prime | NG | 775 | 888 | 1191 |
| Prime | LP | 575 | 670 | 898 |

60Hz (1800RPM)

| Application | Fuel | kWe | kWm | bHp |
|-------------|------|------|------|------|
| Standby HO | NG | 1250 | 1436 | 1924 |
| Standby | NG | 1050 | 1185 | 1589 |
| Standby | LP | 775 | 892 | 1196 |
| LTP | NG | 1050 | 1185 | 1589 |
| LTP | LP | 775 | 892 | 1196 |
| Prime | NG | 925 | 1067 | 1431 |
| Prime | LP | 700 | 803 | 1077 |

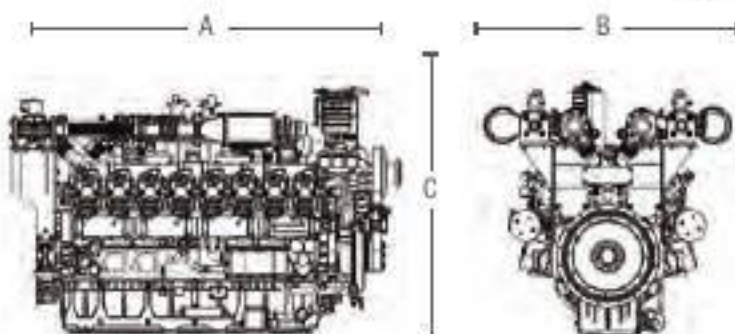

PRODUCT DIMENSIONS

- A – 113.7 in (2,888 mm)
- B – 68.0 in (1,727 mm)
- C – 70.2 in (1,783 mm)

DIESEL ENGINES

A large yellow diesel engine is mounted on a trailer in a warehouse. The engine is the central focus, with various components like hoses and pipes visible. The trailer has the number '030501' on it. The background shows the structural beams of a large industrial building.

- Reliable, durable design built off of a robust marine platform
- Field-proven in applications worldwide
- Diesel engine combines consistent performance and excellent fuel economy with minimum weight
- U.S. EPA Stationary Emergency Certified

kWe values are based on standard assumptions for mechanical and electrical losses. Ratings and performance are subject to site conditions and PSI application and ratings guidelines.

60Hz ENGINES 1800RPM

DIESEL

| Engine Model | Displacement | Application | kWe | kWm |
|--------------|--------------|-------------|------|------|
| PSI 20L-D | 19.6 | Standby | 600 | 670 |
| PSI 20L-D | 19.6 | Standby | 650 | 726 |
| PSI 26L-D | 26.1 | Standby | 700 | 800 |
| PSI 26L-D | 26.1 | Standby | 840 | 946 |
| PSI 40L-D | 39.2 | Standby | 1000 | 1120 |
| PSI 40L-D | 39.2 | Standby | 1300 | 1420 |
| PSI 53L-D | 52.3 | Standby | 1500 | 1680 |
| PSI 53L-D | 52.3 | Standby | 1750 | 1893 |
| PSI 65L-D | 65.4 | Standby | 2000 | 2230 |
| PSI 66L-D | 65.65 | Standby | 2300 | 2500 |
| PSI 66L-D | 65.65 | Standby | 2500 | 2700 |
| PSI 88L-D | 87.5 | Standby | 2800 | 3150 |
| PSI 88L-D | 87.5 | Standby | 3000 | 3350 |
| PSI 88L-D | 87.5 | Standby | 3300 | 3600 |

20L-D

| | |
|-----------------------|---|
| Cylinders | I-6 |
| Induction System | Turbocharged Inter-Cooled |
| Emission Controls | Common Rail |
| Displacement | 19.6 Liters |
| Fuel Injection System | High Pressure Common Rail |
| Compression Ratio | 15:1 |
| Bore & Stroke | 5.91 in x 7.28 in (150 mm x 185 mm) |
| Direction of Rotation | Counter-Clockwise Viewed on Flywheel |
| Dry Weight | 4,608 lbs (2,090 kg) |

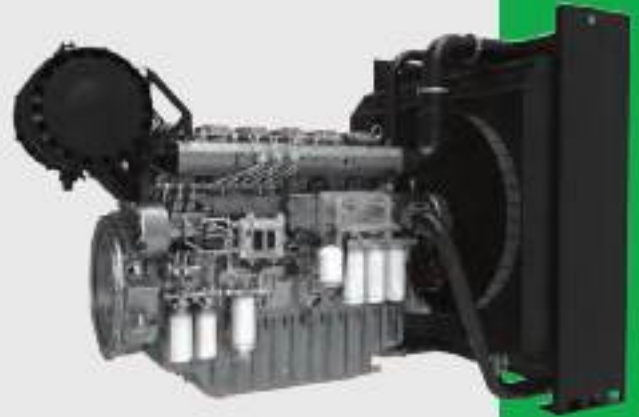

60Hz (1800RPM)

| Application | Fuel | kWe | kWm |
|-------------|--------|-----|-----|
| Standby | Diesel | 600 | 670 |
| Standby | Diesel | 650 | 726 |

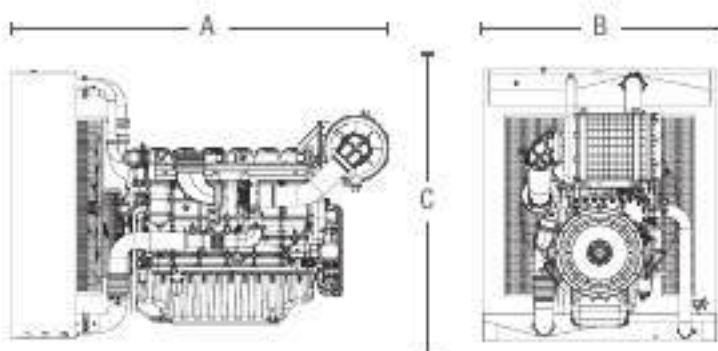

PRODUCT DIMENSIONS

A – 110.2 in (2,798 mm)

B – 66.1 in (1,680 mm)

C – 76.9 in (1,954 mm)

26L-D



| | |
|-----------------------|--|
| Cylinders | V-8 |
| Induction System | Turbocharged Inter-Cooled |
| Emission Controls | Common Rail |
| Displacement | 26.1 Liters |
| Fuel Injection System | High Pressure Common Rail |
| Compression Ratio | 15:1 |
| Bore & Stroke | 5.91 in x 7.28 in (150 mm x 185 mm) |
| Direction of Rotation | Counter-Clockwise Viewed on Flywheel |
| Dry Weight | 6,834 lbs (3,100 kg) |

60Hz (1800RPM)

| Application | Fuel | kWe | kWm |
|-------------|--------|-----|-----|
| Standby | Diesel | 700 | 800 |
| Standby | Diesel | 840 | 946 |

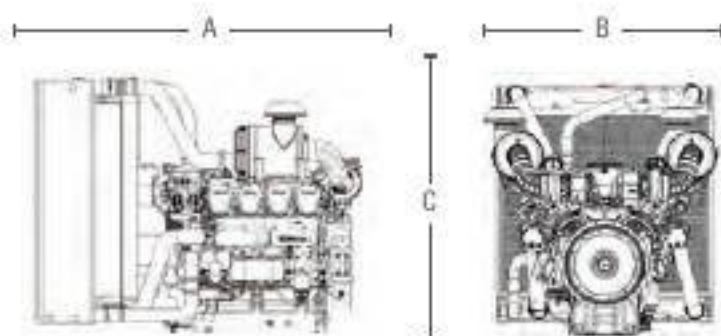

PRODUCT DIMENSIONS

- A – 100.4 in (2,550 mm)
- B – 73.4 in (1,865 mm)
- C – 79.4 in (2,016 mm)

40L-D

| | |
|-----------------------|---|
| Cylinders | V-12 |
| Induction System | Turbocharged Inter-Cooled |
| Emission Controls | Common Rail |
| Displacement | 39.2 Liters |
| Fuel Injection System | High Pressure Common Rail |
| Compression Ratio | 15:1 |
| Bore & Stroke | 5.91 in x 7.28 in (150 mm x 185 mm) |
| Direction of Rotation | Counter-Clockwise Viewed on Flywheel |
| Dry Weight | 7,915 lbs (3,590 kg) |



60Hz (1800RPM)

| Application | Fuel | kWe | kWm |
|-------------|--------|------|------|
| Standby | Diesel | 1000 | 1120 |
| Standby | Diesel | 1300 | 1420 |

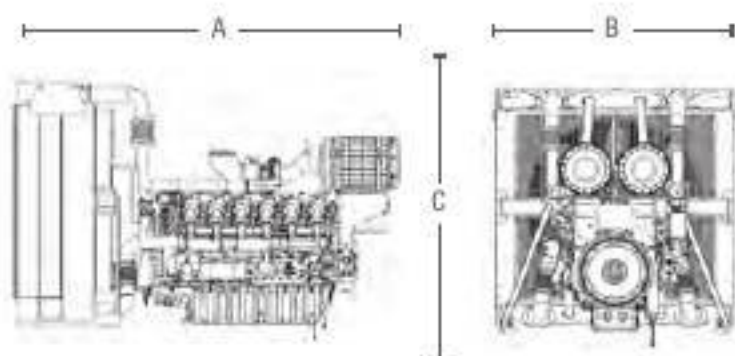

PRODUCT DIMENSIONS

A – 138.8 in (3,525 mm)

B – 88.3 in (2,242 mm)

C – 88.3 in (2,243 mm)

53L-D



| | |
|-----------------------|---|
| Cylinders | V-16 |
| Induction System | Turbocharged Inter-Cooled |
| Emission Controls | Common Rail |
| Displacement | 52.3 Liters |
| Fuel Injection System | High Pressure Common Rail |
| Compression Ratio | 15:1 |
| Bore & Stroke | 5.91 in x 7.28 in (150 mm x 185 mm) |
| Direction of Rotation | Counter-Clockwise Viewed on Flywheel |
| Dry Weight | 11,464 lbs (5,200 kg) |

60Hz (1800RPM)

| Application | Fuel | kWe | kWm |
|-------------|--------|------|------|
| Standby | Diesel | 1500 | 1680 |
| Standby | Diesel | 1750 | 1893 |

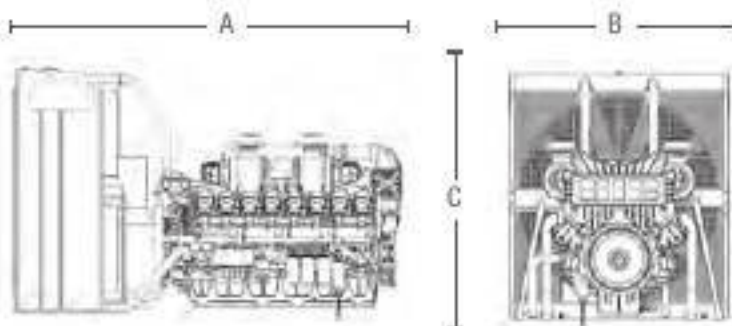

PRODUCT DIMENSIONS

- A – 156.2 in (3,967 mm)
- B – 88.1 in (2,237 mm)
- C – 97.8 in (2,485 mm)

65L-D

| | |
|-----------------------|---|
| Cylinders | V-20 |
| Induction System | Turbocharged Inter-Cooled |
| Emission Controls | Common Rail |
| Displacement | 65.4 Liters |
| Fuel Injection System | High Pressure Common Rail |
| Compression Ratio | 15:1 |
| Bore & Stroke | 5.91 in x 7.28 in (150 mm x 185 mm) |
| Direction of Rotation | Counter-Clockwise Viewed on Flywheel |
| Dry Weight | 14,661 lbs (6,650 kg) |



60Hz (1800RPM)

| Application | Fuel | kWe | kWm |
|-------------|--------|------|------|
| Standby | Diesel | 2000 | 2230 |

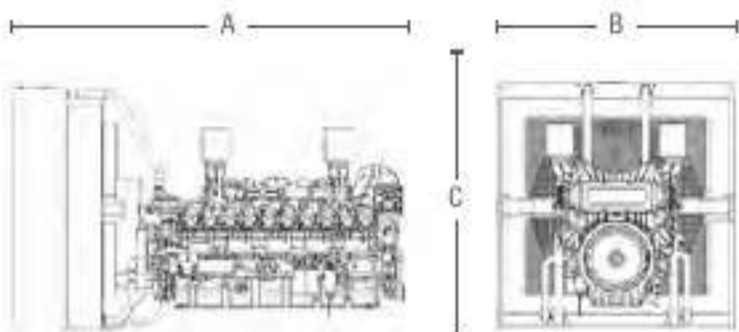

PRODUCT DIMENSIONS

A – 181.5 in (4,611 mm)

B – 108.5 in (2,756 mm)

C – 113 in (2,870 mm)

66L-D



| | |
|-----------------------|---|
| Cylinders | V-12 |
| Induction System | Turbocharged Inter-Cooled |
| Emission Controls | Common Rail |
| Displacement | 65.65 Liters |
| Fuel Injection System | High Pressure Common Rail |
| Compression Ratio | 16.5:1 |
| Bore & Stroke | 7.09 in x 8.46 in (180 mm x 215 mm) |
| Direction of Rotation | Counter-Clockwise Viewed on Flywheel |
| Dry Weight | 21,054 lbs (9550 kg) |

60Hz (1800RPM)

| Application | Fuel | kWe | kWm |
|-------------|--------|------|------|
| Standby | Diesel | 2300 | 2500 |
| Standby | Diesel | 2500 | 2700 |

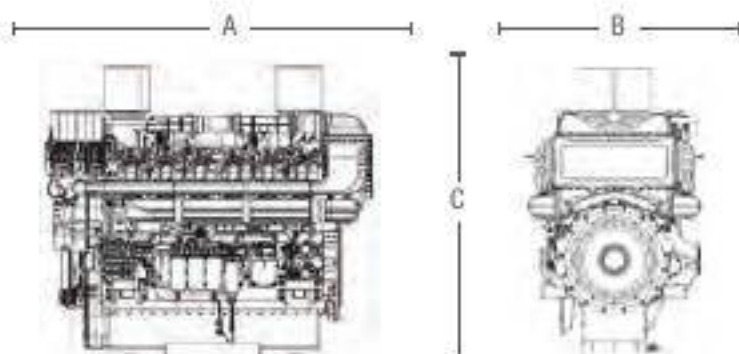

PRODUCT DIMENSIONS

- A – 112.6 in (2,859 mm)
- B – 60.8 in (1,544 mm)
- C – 103 in (2,616 mm)

88L-D

| | |
|-----------------------|---|
| Cylinders | V-16 |
| Induction System | Turbocharged Inter-Cooled |
| Emission Controls | Common Rail |
| Displacement | 87.5 Liters |
| Fuel Injection System | High Pressure Common Rail |
| Compression Ratio | 16.5:1 |
| Bore & Stroke | 7.09 in x 8.46 in (180 mm x 215 mm) |
| Direction of Rotation | Counter-Clockwise Viewed on Flywheel |
| Dry Weight | 25,353 lbs (11,500 kg) |



60Hz (1800RPM)

| Application | Fuel | kWe | kWm |
|-------------|--------|------|------|
| Standby | Diesel | 2800 | 3150 |
| Standby | Diesel | 3000 | 3350 |
| Standby | Diesel | 3300 | 3600 |

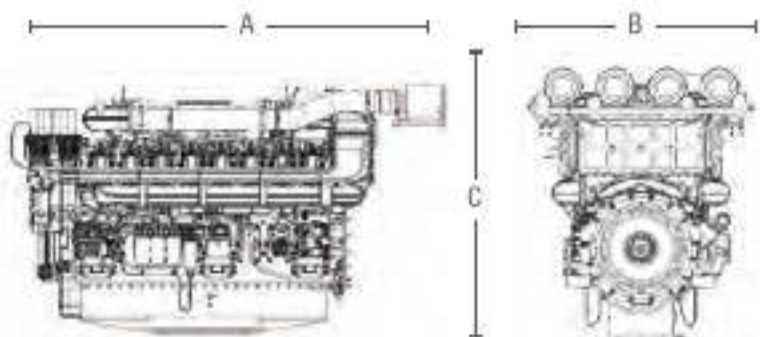

PRODUCT DIMENSIONS

A – 163.8 in (4,161 mm)

B – 76.9 in (1,952 mm)

C – 97.2 in (2,468 mm)

ENGINE CONTROLS

Superior engine performance is driven by an ECU that integrates and coordinates all critical functions including: Governor, Variable Ignition Timing, Air Fuel Ratio Control, Knock Suppression and Engine Protection.

- Delivers Strong Load Acceptance to Allow Units to be Capable of Compliance with ISO 8528 – G2
- U.S. Proven PSI ECU, Fuel System & Engine Control
- Engine Protection
- CANBUS J1939 Interface
- MasterTrak Telematics

MASTERTRAK

MasterTrak Keeps You Connected to Your Bottom Line

MasterTrak Advanced Telematics is an industry-leading asset-management tool that monitors critical equipment in real time, 24/7 for health, location, utilization, security, maintenance, compliance and other information.



Improved equipment health, location and utilization with 24/7/365 monitoring



Alerts, notifications and reports prevent shutdowns, theft or damage



Custom reports integrate across business systems with targeted information



Tailored solutions to fit your industry



Easy online and mobile access with a rich suite of applications



Wide coverage reaches you in the office, the field or on-the-go

GLOBAL NETWORK



- Operations in 55 countries with 500 authorized service centers worldwide
- Large volume manufacturing, engine testing & certification



- 80,000 Employees
- 2,500 Engineers



CONTACT US

Power Solutions International, Inc.
201 Mittel Drive, Wood Dale, IL 60191

P: 630.350.9400 | F: 630.350.9588

www.psiengines.com