

YC4D65-D20

Prime power: 44 kW @ 1800 r/min

Standby power: 48.4 kW @ 1800 r/min

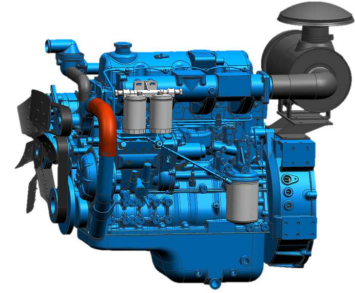

Definitions

Prime Power

It corresponds to the prime rated power (PRP) of GB/T 2820 and ISO 8528, and refers to the maximum power accessible at the variable load for an unlimited running hours per year, with the maintenance intervals and procedures being carried out as prescribed by Yuchai, and the allowed average output power within 24 h shall not be higher than 70% of the prime power.

Standby Power

It corresponds to the emergency standby power (ESP) of GB/T 2820 and ISO 8528, and refers to the maximum power accessible at a certain variable load series in the event of a utility power outage or under test conditions for an limited running hours up to 200 h per year, with the maintenance intervals and procedures being carried out as prescribed by Yuchai. The allowed average output power within 24 h shall not be higher than 70% of the standby power.

Main technical parameters

Number of cylinders	4
Configuration	Vertical, in-line
Aspiration	Normally Aspirated
Combustion system	Direct injection
Compression ratio	17.5:1
Bore	108 mm
Stroke	115 mm
Displacement	4.214 L
Rotation	Counterclockwise (viewed from the flywheel end)
Firing order (viewed from the belt pulley end)	1-3-4-2
Dry weight (without radiator)	420 kg
Wet weight (without radiator)	450 kg

Centerline deviation relative to the crankshaft center gravity
.....-9 mm

Moments of rotation inertia

Engine	1.068 kg·m ²
Flywheel	0.89 kg·m ²

Performance rating

Speed droop	≤ 3 %
Steady state speed band	≤ 0.5 %

Overall dimensions

Length (from front end of radiator to rear end of air filter)	1298 mm
Width	732 mm
Height (with radiator and mounting support).....	999 mm

Test conditions

Ambient temperature	25 °C
Atmospheric pressure.....	100 kPa
Relative humidity	30 %
Max. operating intake resistance	≤ 5 kPa
Exhaust backpressure limit.....	≤ 10 kPa
Fuel temperature (fuel inlet pump).....	38±2 °C

Centre of gravity (dry engine, with the center of the rear end face of the flywheel shell as the origin)

From the rear end face of the flywheel.....	387 mm
Height relative to the center of the crankshaft.....	140 mm

Attention: Unless otherwise explicitly specified, all parameter data are measured under standard test condition as above. If the engine is operated under other test conditions rather than the test condition above, it shall be adjusted properly according to the actual environment. Contact the Yuchai Technical Service Department for details.

Matching parameters

Designation	Unit	Matching parameters	
		Standby	Prime
		60 Hz @ 1800 r/min	
Gross engine power	kW	48.4	44
Net engine power	kW	45.4	41
Fan power consumption (belt pulley driven)	kW	2	2
Other power loss	kW	1	1
Mean effective pressure	MPa	0.77	0.7
Intake air flow	m ³ /min	2.5	2.4
Exhaust temperature limit (after turbocharger)	°C	650	580
Exhaust flow	m ³ /min	2.88	2.62
Boost pressure ratio		/	/
Thermal efficiency	%	36.1	38.4
Mean piston speed	m/s	6.9	6.9
Coolant flow	L/min	140	140
Cooling fan air flow	m ³ /min	142	142
Typical gen-set electrical output (power factor:0.8)	kW	38	34
	kVA	48	43
Assumed generator efficiency	%	86	86

Energy balance parameters

Note: The calorific value of diesel is 42,770 kJ/kg

Designation	Unit	Energy balance parameters	
		Standby	Prime
		60 Hz @ 1800 r/min	
Total fuel chemical energy	kW	134	114
Output power (gross)	kW	48.4	44
Output power (net)	kW	45.4	41
Fan power consumption	kW	2	2
Other power loss	kW	1	1
Heat dissipation capacity(coolant circulation)	kW	26.6	24.2
Heat dissipation of exhaust	kW	40	34
Heat dissipation of thermal radiation	kW	1	1

Heat dissipating capacity of Yuchai engine with D7300-1301100 radiator at an ambient temperature of 50 °C is as follows:

Designation	Unit	Energy balance parameters	
		Standby	Prime
		60 Hz @ 1800 r/min	
Total fuel chemical energy	kW	136	117
Output power (gross)	kW	48	44
Output power (net)	kW	43	41
Fan power consumption	kW	2	2
Other power loss	kW	1	1
Heat dissipation capacity(coolant circulation)	kW	25.3	23.1
Heat dissipation of exhaust	kW	41	35
Heat dissipation of thermal radiation	kW	1	1

Cooling system

Total coolant capacity.....	22 L
Engine coolant capacity.....	7.35 L
Radiator coolant capacity.....	12 L
Pipeline coolant capacity.....	2 L
Engine max. outlet coolant temperature.....	97°C
Pressure difference between inlet and outlet of water pump (max. hydrostatic head).....	(60~70) kPa
Thermostat operation temperature	
Initial open.....	(70±2)°C
full open.....	<80°C
Max. coolant temperature rise:	
-Standby power.....	8°C
-Prime power.....	7°C

Radiator

Cooling area.....	24m ²
Dry weight.....	61kg
Core material.....	Copper
Number of lines.....	/
Density of core.....	13 cooling fins/inch
Width of core.....	560 mm
Height of core.....	560 mm
Min. pressure of pressure cap.....	(50±5)kPa
Coolant resistance limit.....	15 kPa

Coolant pump

Rotation speed.....	3200 r/min
Drive mode.....	Pulley driven

Fan

Diameter.....	480 mm
Drive ratio.....	1.78:1
Material.....	Steel
Number of blades.....	6
Type.....	Blowing

Intake system

Air filter

Max. intake resistance:	
-Clean air filter	2.45 kPa
-Dirty air filter	5 kPa
-Air filter type.....	Dry-type, filter cartridge of paper

Inclination

Transverse inclination (volume of engine oil sump: 11 L)	± 10°
longitudinal inclination (volume of engine oil sump: 11 L)	± 10°

Fuel system

Injection system...Mechanical pump + mechanical governor

Injector

Type.....	Mechanical
Injector opening pressure	(23~24) MPa

Fuel pump

Drive mode	Gear driven
Fuel delivery pump flow @1800 rpm	0.25 L/min
Max. fuel inlet temperature limit.....	70 °C
Allowed fuel inlet pressure of front end of fuel delivery pump (absolute pressure).....	(35~100) kPa
Maximum fuel return pressure of fuel pump	20 kPa

Fuel filter

Rated flow.....	0.66 L/min
Max. original resistance	4.5 kPa
Filter efficiency:	
For particles of 25 μm.....	99 %
For particles of 10 μm.....	85 %

Fuel consumption

Note: The density of diesel is 0.835 kg/L.

Load condition	1800 r/min	
	g/(kW·h)	L/h
Standby	233	13.5
Prime	219	11.5
75% prime	217	8.6
50% prime	225	5.9

Lubricating system

Total oil capacity(dry engine) 13.7 L
 Total oil capacity(oil change) 11.7 L
 Oil sump capacity - low level/high level 8.1/13.7 L
 Max. oil temperature (in oil sump) 120 °C
 Operating oil temperature(in oil sump)..... (90~115) °C
 Oil pressure(idle speed) ≥ 120 kPa
 Oil pressure(rated speed)..... (250~500) kPa
 Oil-fuel consumption ratio < 0.2 %

Oil filter

The filtering efficiency at the rated flow of 30 L/min and the assembly initial resistance ≤ 25 kPa:

For $15\mu\text{m} \leq \text{particles} < 20\mu\text{m}$ > 75 %
 For $20\mu\text{m} \leq \text{particles} < 30\mu\text{m}$ > 95 %
 For $30\mu\text{m} \leq \text{particles} < 40\mu\text{m}$ > 99 %
 For $\text{particles} \geq 40\mu\text{m}$ > 99.9999 %

Electric system

Type.....Negative ground

Charger

Voltage 28V
 Output current 35A

Starter

Type Electric start, 1
 Voltage 24V
 Power 5 kW
 Number of teeth of flywheel..... 130
 Number of teeth of starter..... 11

Cold start (test data, for reference only)

24 V				
Battery specification×quantity:12V/120Ah×2				
Starting temperature	°C	-15	-20	-25
Starting speed	r/min	220	180	155
Starting current	A	225	275	323
Starting voltage	V	19.8	18.3	17.7
Starting time	s	2.2	2.5	3.0
Preheating time	s	25	40	50

Auxiliary intake heater

Type..... Grating-type
 Specification 1.8 kW

Water preheater

Recommended specification. 2 kW/220 V
 Engine preheater water outlet interface..... NPT 1/4
 Engine preheater water inlet interface NPT 3/8

Oil heater

Recommended specification. 90 W/220 V
 Interface (oil sump, 1)..... M22×1.5

Exhaust system

Max. exhaust backpressure..... 10 kPa
 Inner diameter of exhaust port pipe..... $\Phi 48$ mm

Noise

Noise data (44 kW @ 1800 r/min)

Position	Noise, dB(A)
1	85.5
2	90.1
3	87.5
4	95.5
5	89.2
6	91.1
7	85.3
8	86.3
9	90.7

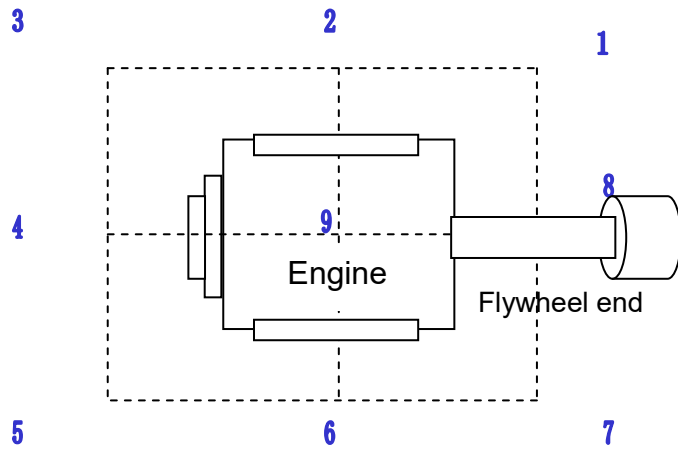

Noise spectrum (44 kW @ 1800 r/min)

Frequency, Hz	Noise, dB(A)
63	40
125	65
250	67
500	71
1K	75
2K	81
4K	80
8K	71

