

YC6C1070-D31

Prime power: 715 kW @ 1500 r/min

Standby power: 787 kW @ 1500 r/min



Definitions

Prime Power

It corresponds to the prime rated power (PRP) of GB/T 2820 and ISO 8528, and refers to the maximum power accessible at the variable load for an unlimited running hours per year, with the maintenance intervals and procedures being carried out as prescribed by Yuchai, and the allowed average output power within 24 h shall not be higher than 70% of the prime power.

Standby Power

It corresponds to the emergency standby power (ESP) of GB/T 2820 and ISO 8528, and refers to the maximum power accessible at a certain variable load series in the event of a utility power outage or under test conditions for an limited running hours up to 200 h per year, with the maintenance intervals and procedures being carried out as prescribed by Yuchai. The allowed average output power within 24 h shall not be higher than 70% of the standby power.

Main technical parameters

Number of cylinders	6
Configuration	Vertical, in-line
Aspiration	Turbocharged, air-air intercooled
Combustion system	Direct injection
Compression ratio	14.5:1
Bore	200 mm
Stroke	210 mm
Displacement	39.58 L
Rotation	Counterclockwise (viewed from the flywheel end)
Firing order (viewed from the belt pulley end)	1-5-3-6-2-4
Dry weight (without radiator)	4500 kg
Wet weight (without radiator)	4780 kg

Overall dimensions

Length (from front end of radiator to rear end of air filter)	3396 mm
Width	1655 mm
Height (with radiator and mounting support)	2194 mm

Centre of gravity (dry engine, with the center of the rear end face of the flywheel shell as the origin)

From the rear end face of the flywheel	1006.8 mm
Height relative to the center of the crankshaft	0.3 mm

Centerline deviation relative to the crankshaft center gravity	261.4 mm
--	----------

Moments of rotation inertia

Engine	24.19 kg·m ²
Flywheel	15.38 kg·m ²

Performance rating

Speed droop	≤1 %
Steady state speed band	≤0.5 %

Test conditions

Ambient temperature	25 °C
Atmospheric pressure	100 kPa
Relative humidity	30 %
Max. operating intake resistance	≤5 kPa
Exhaust backpressure limit	≤10 kPa
Fuel temperature (fuel inlet pump)	38±2 °C

Attention: Unless otherwise explicitly specified, all parameter data are measured under standard test condition as above. If the engine is operated under other test conditions rather than the test condition above, it shall be adjusted properly according to the actual environment. Contact the Yuchai Technical Service Department for details.

Matching parameters

Designation	Unit	Matching parameters	
		Standby	Prime
		50 Hz @ 1500 r/min	
Gross engine power	kW	787	715
Net engine power	kW	757	685
Fan power consumption (belt pulley driven)	kW	29	29
Other power loss	kW	1	1
Mean effective pressure	MPa	1.59	1.45
Intake air flow	m ³ /min	68.5	62.5
Exhaust temperature limit (after turbocharger)	°C	550	550
Exhaust flow	m ³ /min	163.6	148.5
Boost pressure ratio		3.06	2.86
Thermal efficiency	%	39.8	39.7
Mean piston speed	m/s	10.5	10.5
Coolant flow	L/min	870	870
Cooling fan air flow	m ³ /min	965	965
Typical gen-set electrical output (power factor:0.8)	kW	710	650
	kVA	888	813
Assumed generator efficiency	%	93.8	94.9

Energy balance parameters

Note: The calorific value of diesel is 42,770 kJ/kg

Designation	Unit	Energy balance parameters	
		Standby	Prime
		50 Hz @ 1500 r/min	
Total fuel chemical energy	kW	1977	1801
Output power (gross)	kW	787	715
Output power (net)	kW	757	685
Fan power consumption	kW	29	29
Other power loss	kW	1	1
Heat dissipation capacity(coolant circulation)	kW	372	328
Heat dissipation capacity(intake intercooled system)	kW	212	195
Heat dissipation of exhaust	kW	552	513
Heat dissipation of thermal radiation	kW	54	50

Heat dissipating capacity of Yuchai engine with Yuchai radiator at an ambient temperature of 50 °C is as follows:

Designation	Unit	Energy balance parameters	
		Standby	Prime
		50 Hz @ 1500 r/min	
Total fuel chemical energy	kW	1995	1817
Output power (gross)	kW	787	715
Output power (net)	kW	757	685
Fan power consumption	kW	29	29
Other power loss	kW	1	1
Heat dissipation capacity(coolant circulation)	kW	380	333
Heat dissipation capacity(intake intercooled system)	kW	221	197
Heat dissipation of exhaust	kW	552	521
Heat dissipation of thermal radiation	kW	55	51

Cooling system

Total coolant capacity.....	230 L
Engine coolant capacity.....	90 L
Radiator coolant capacity.....	127 L
Pipeline coolant capacity.....	13 L
Engine max. outlet coolant temperature.....	97°C
Pressure difference between inlet and outlet of water pump (max. hydrostatic head).....	150 kPa
Thermostat operation temperature	
Initial open.....	(75±2)°C
full open.....	<(85±2)°C
Max. coolant temperature rise:	
-Standby power.....	8°C
-Prime power.....	7°C

Radiator

Cooling area.....	300 m ²
Dry weight.....	598kg
Core material.....	Copper
Number of lines.....	134
Density of core.....	13 cooling fins/inch
Width of core.....	1685 mm
Height of core.....	1750 mm
Min. pressure of pressure cap.....	(50±5)kPa
Coolant resistance limit.....	25 kPa

Intercooler

Cooling area.....	152 m ²
Core material.....	Copper
Number of lines.....	102
Density of core.....	12 cooling fins/inch
Width of core.....	1664 mm
Height of core.....	1730 mm
Air resistance limit.....	15 kPa

Coolant pump

Rotation speed.....	2864 r/min
Drive mode.....	Gear driven

Fan

Diameter.....	1321 mm
Drive ratio.....	1.36:1
Material.....	Steel
Number of blades.....	8
Type.....	Blowing

Intake system

Air filter

Max. intake resistance:	
-Clean air filter	2.45 kPa
-Dirty air filter	5 kPa
-Air filter type.....	dry-type, filter cartridge of paper

Inclination

Transverse inclination/longitudinal inclination (volume of engine oil sump: 155 L)	20°/ 10°
--	----------

Fuel system

Injection system.....	Electronic unit pump
-----------------------	----------------------

Injector

Type.....	Mechanical
Injector opening pressure	(26~27) MPa

Fuel pump

Drive mode	Gear driven
Fuel delivery pump flow @1,500 rpm	10 L/min
Max. fuel inlet temperature limit.....	75 °C
Allowed fuel inlet pressure of front end of fuel delivery pump (absolute pressure).....	100 kPa
Maximum fuel return pressure of fuel pump	20 kPa

Fuel filter

Pre- filter

Rated flow.....	30 L/min
Max. original resistance	7 kPa
Water separation efficiency at the rated flow	≥95 %
Filter efficiency:	
For particles of 25 μm.....	99 %
For particles of 10 μm.....	85 %

Fine- filter

Rated flow.....	30 L/min
Max. original resistance	10 kPa
Filtering efficiency:	
For particles of 10 μm.....	99.8 %
For particles of 3 μm.....	98.5 %

Fuel consumption

Note: The density of diesel is 0.835 kg/L.

Load condition	1500 r/min	
	g/(kW·h)	L/h
Standby	212.3	200.1
Prime	212.1	181.6
75% prime	227.5	146.1
50% prime	238.0	101.9

Lubricating system

Total oil capacity(dry engine) 160 L
 Total oil capacity(oil change) 155 L
 Oil sump capacity - low level/high level 130/160 L
 Max. oil temperature (in oil sump) 120 °C
 Operating oil temperature(in oil sump)..... (90~115) °C
 Oil pressure(idle speed) ≥120 kPa
 Oil pressure(rated speed)..... (250~700) kPa
 Oil-fuel consumption ratio..... <0.1 %

Oil filter

The filtering efficiency at the rated flow of 44 L/min and the assembly initial resistance ≤25 kPa:

For 15µm≤particles<20µm.....>75 %
 For 20µm≤particles<30µm.....>95%
 For 30µm≤particles<40µm.....>99%
 For particles≥40µm.....>99.9999%

Electric system

Type.....Negative ground

Charger

Voltage 28V
 Output current 35A

Starter

TypeElectric start, 2
 Voltage 24V
 Power7.5 kW
 Number of teeth of flywheel..... 153
 Number of teeth of starter..... 10

Cold start (test data, for reference only)

24 V					
Battery specification × quantity: ≥12V/195Ah×4. And the min CCA of Battery should be 1100A when apply to cold area and plateau area.					
Starting temperature	°C	-15	-20	-25	-30
Starting speed	r/min	140	130	110	105
Starting current	A	700	776	856	1100
Starting voltage	V	21.64	21.86	19.71	18.02
Starting time	s	4	5.5	5.0	5.5
Preheating time	s	0	20	40	60

Auxiliary intake heater

Type...../
 Specification/

Water preheater

Recommended specification.6 kW/220 V
 Engine preheater water outlet interface..... NPT 1
 Engine preheater water inlet interface NPT 1

Oil heater

Recommended specification.1kW/220 V
 Interface (oil sump, 2)..... M22×1.5

Exhaust system

Max. exhaust backpressure..... 10 kPa
 Inner diameter of exhaust port pipe.....Φ200 mm

Noise

Noise data (715 kW @ 1500 r/min)

Position	Noise, dB(A)
1	100.7
2	102.9
3	104.7
4	102.3
5	105.7
6	99.0
7	105.5
8	102.1
9	100.2
10	101.5
11	100.9
12	104.1

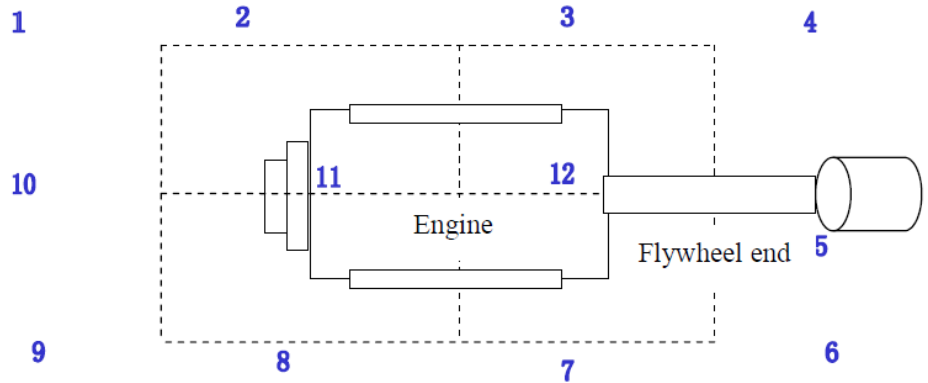

Noise spectrum (715 kW @ 1500 r/min)

Frequency, Hz	Noise, dB(A)
63	51
125	69
250	80
500	88
1K	94
2K	93
4K	92
8K	86
16K	72

