

YC6MK350-D30

Prime power: 235 kW @ 1500 r/min

Standby power: 259 kW @ 1500 r/min

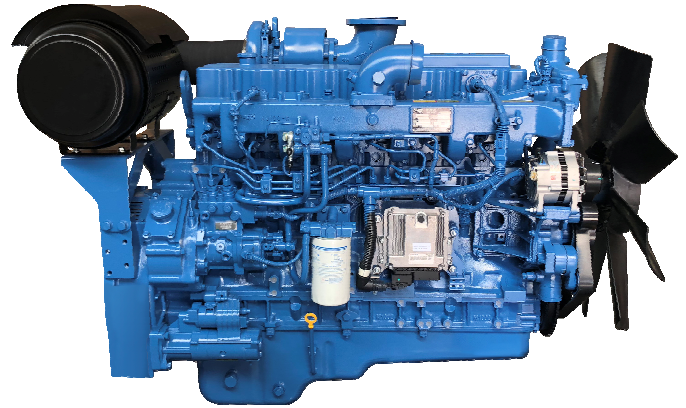

Definitions

Prime Power

It corresponds to the prime rated power (PRP) of GB/T 2820 and ISO 8528, and refers to the maximum power accessible at the variable load for an unlimited running hours per year, with the maintenance intervals and procedures being carried out as prescribed by Yuchai, and the allowed average output power within 24 h shall not be higher than 70% of the prime power.

Standby Power

It corresponds to the emergency standby power (ESP) of GB/T 2820 and ISO 8528, and refers to the maximum power accessible at a certain variable load series in the event of a utility power outage or under test conditions for an limited running hours up to 200 h per year, with the maintenance intervals and procedures being carried out as prescribed by Yuchai. The allowed average output power within 24 h shall not be higher than 70% of the standby power.

Main technical parameters

| | |
|--|---|
| Number of cylinders | 6 |
| Configuration | Vertical, in-line |
| Aspiration | Turbocharged, air-air intercooled |
| Combustion system | Direct injection |
| Compression ratio | 16.8:1 |
| Bore | 123 mm |
| Stroke | 145 mm |
| Displacement | 10.34 L |
| Rotation | Counterclockwise (viewed from the flywheel end) |
| Firing order (viewed from the belt pulley end) | 1-5-3-6-2-4 |
| Dry weight (without radiator) | 1030 kg |
| Wet weight (without radiator) | 1080 kg |

Overall dimensions

| | |
|---|---------|
| Length (from front end of radiator to rear end of air filter) | 2088 mm |
| Width | 1130 mm |
| Height (with radiator and mounting support) | 1392 mm |

Centre of gravity (dry engine, with the center of the rear end face of the flywheel shell as the origin)

| | |
|---|--------|
| From the rear end face of the flywheel | 567 mm |
| Height relative to the center of the crankshaft | 181 mm |

Centerline deviation relative to the crankshaft center gravity

.....-2 mm

Moments of rotation inertia

| | |
|----------------|------------------------|
| Engine | 3.02 kg·m ² |
| Flywheel | 2.35 kg·m ² |

Performance rating

| | |
|-------------------------------|------------------|
| Speed droop | ≤0.5 % |
| Steady state speed band | ≤0.5 % |
| Govern | Electric control |

Test conditions

| | |
|--|---------|
| Ambient temperature | 25 °C |
| Atmospheric pressure | 100 kPa |
| Relative humidity | 30 % |
| Max. operating intake resistance | ≤5 kPa |
| Exhaust backpressure limit | ≤10 kPa |
| Fuel temperature (fuel inlet pump) | 38±2 °C |

Attention: Unless otherwise explicitly specified, all parameter data are measured under standard test condition as above. If the engine is operated under other test conditions rather than the test condition above, it shall be adjusted properly according to the actual environment. Contact the Yuchai Technical Service Department for details.

Matching parameters

| Designation | Unit | Matching parameters | |
|--|---------------------|---------------------|-------|
| | | Standby | Prime |
| | | 50 Hz @ 1500 r/min | |
| Gross engine power | kW | 259 | 235 |
| Net engine power | kW | 245 | 223 |
| Fan power consumption (belt pulley driven) | kW | 11 | 11 |
| Other power loss | kW | 3 | 1 |
| Mean effective pressure | MPa | 2.00 | 1.82 |
| Intake air flow | m ³ /min | 15.8 | 15.3 |
| Exhaust temperature limit (after turbocharger) | °C | 580 | 580 |
| Exhaust flow | m ³ /min | 38.4 | 35.8 |
| Boost pressure ratio | | 2.87 | 2.77 |
| Thermal efficiency | % | 41.8 | 41.2 |
| Mean piston speed | m/s | 7.25 | 7.25 |
| Coolant flow | L/min | 366 | 366 |
| Cooling fan air flow | m ³ /min | 612 | 612 |
| Typical gen-set electrical output (power factor:0.8) | kW | 220 | 200 |
| | kVA | 275 | 250 |
| Assumed generator efficiency | % | 89.8 | 89.7 |

Energy balance parameters

Note: The calorific value of diesel is 42,770 kJ/kg

| Designation | Unit | Energy balance parameters | |
|--|------|---------------------------|-------|
| | | Standby | Prime |
| | | 50 Hz @ 1500 r/min | |
| Total fuel chemical energy | kW | 619 | 570 |
| Output power (gross) | kW | 259 | 235 |
| Output power (net) | kW | 245 | 223 |
| Fan power consumption | kW | 11 | 11 |
| Other power loss | kW | 3 | 1 |
| Heat dissipation capacity(coolant circulation) | kW | 136 | 131 |
| Heat dissipation capacity(intake intercooled system) | kW | 45 | 40 |
| Heat dissipation of exhaust | kW | 162 | 148 |
| Heat dissipation of thermal radiation | kW | 17 | 16 |

Heat dissipating capacity of Yuchai engine with MKLF0-1316100 radiator at an ambient temperature of 50°C is as follows:

| Designation | Unit | Energy balance parameters | |
|--|------|---------------------------|-------|
| | | Standby | Prime |
| | | 50 Hz @ 1500 r/min | |
| Total fuel chemical energy | kW | 641 | 586 |
| Output power (gross) | kW | 259 | 235 |
| Output power (net) | kW | 245 | 223 |
| Fan power consumption | kW | 11 | 11 |
| Other power loss | kW | 3 | 1 |
| Heat dissipation capacity(coolant circulation) | kW | 138 | 132 |
| Heat dissipation capacity(intake intercooled system) | kW | 48 | 45 |
| Heat dissipation of exhaust | kW | 177 | 157 |
| Heat dissipation of thermal radiation | kW | 19 | 17 |

Cooling system

| | |
|---|---------|
| Total coolant capacity..... | 65 L |
| Engine coolant capacity..... | 21 L |
| Radiator coolant capacity..... | 40 L |
| Pipeline coolant capacity..... | 4 L |
| Engine max. outlet coolant temperature..... | 99℃ |
| Thermostat operation temperature | |
| Initial open..... | (80±2)℃ |
| full open..... | <90℃ |
| Max. coolant temperature rise: | |
| -Standby power..... | 8.5℃ |
| -Prime power..... | 8.2℃ |

Radiator

| | |
|------------------------------------|---------------------|
| Cooling area..... | 111.4m ² |
| Dry weight..... | 155kg |
| Core material..... | Aluminum |
| Width of core..... | 1050 mm |
| Height of core..... | 1060 mm |
| Thickness of core..... | 96 mm |
| Min. pressure of pressure cap..... | (50±5)kPa |
| Coolant resistance limit..... | 30 kPa |

Intercooler

| | |
|---------------------------|---------------------|
| Cooling area..... | 53.2 m ² |
| Core material..... | Aluminum |
| Width of core..... | 1050 mm |
| Height of core..... | 1060 mm |
| Thickness of core..... | 96 mm |
| Air resistance limit..... | 10 kPa |

Coolant pump

| | |
|---------------------|---------------|
| Rotation speed..... | 2460 r/min |
| Drive mode..... | Pulley driven |

Fan

| | |
|-----------------------|----------------------|
| Diameter..... | 850 mm |
| Drive ratio..... | 1.04:1 |
| Material..... | Engineering plastics |
| Number of blades..... | 8 |
| Type..... | Blowing |

Intake system

Air filter

| | |
|-------------------------------------|-------------------------------------|
| Max. intake resistance: | |
| -Clean air filter | 3.5 kPa |
| -Dirty air filter | 5 kPa |
| -Warning of intake resistance | 6.2 kPa |
| Air filter type..... | Dry-type, filter cartridge of paper |

Inclination

| | |
|---|----------|
| Transverse inclination/longitudinal inclination (volume of engine oil sump: 28 L) | 15°/ 20° |
|---|----------|

Fuel system

| | |
|-----------------------|---------------------------|
| Injection system..... | High pressure common rail |
|-----------------------|---------------------------|

Injector

| | |
|--------------------------------|---|
| Type..... | Electronically controlled, with multiple jets |
| Injector opening pressure..... | Electronically controlled |

Fuel pump

| | |
|---|--------------|
| Drive mode | Gear driven |
| Fuel delivery pump flow @1,500 rpm | 1.5 L/min |
| Max. fuel inlet temperature limit..... | 70 °C |
| Allowed fuel inlet pressure of front end of fuel delivery pump (absolute pressure)..... | (35~100) kPa |
| Maximum fuel return pressure of fuel pump | 20 kPa |

Fuel filter

Pre- filter

| | |
|---|---------|
| Rated flow..... | 7 L/min |
| Max. original resistance | 12 kPa |
| Water separation efficiency at the rated flow | ≥95 % |
| Filter efficiency: | |
| For particles of 25 μm..... | 99 % |
| For particles of 10 μm..... | 85 % |

Fine- filter

| | |
|-----------------------------------|-----------|
| Rated flow..... | 7 L/min |
| Max. original resistance | 8 kPa |
| Filtering efficiency: | |
| For particles of ≥15 μm | ≥99.999 % |
| For particles of (10~15) μm | ≥99.8 % |
| For particles of (8~10) μm | ≥96.6 % |
| For particles of (5~8) μm | ≥98.9 % |
| For particles of (3~5) μm | ≥98.5 % |

Fuel consumption

Note: The density of diesel is 0.835 kg/L.

| Load condition | 1500 r/min | |
|----------------|------------|------|
| | g/(kW·h) | L/h |
| Standby | 201.2 | 62.4 |
| Prime | 204.4 | 57.5 |
| 75% prime | 213.9 | 45.1 |
| 50% prime | 230.6 | 32.5 |

Lubricating system

- Total oil capacity(dry engine)30 L
- Total oil capacity(oil change)28 L
- Oil sump capacity - low level/high level22/28 L
- Max. oil temperature (in oil sump)120 °C
- Operating oil temperature(in oil sump)..... (80~115) °C
- Oil pressure(idle speed) ≥120 kPa
- Oil pressure(rated speed)..... (250~500) kPa
- Oil-fuel consumption ratio..... <0.1 %

Oil filter

The filtering efficiency at the rated flow of 120 L/min and the assembly initial resistance ≤25 kPa:

- For 15µm≤particles<20µm.....>75 %
- For 20µm≤particles<30µm.....>95%
- For 30µm≤particles<40µm.....>99%
- For particles≥40µm.....>99.9999%

Electric system

Type.....Negative ground

Charger

- Voltage 28V
- Output current 55A

Starter

- Type Electric start, 1
- Voltage 24V
- Power9kW
- Number of teeth of flywheel..... 119
- Number of teeth of starter..... 11

Cold start (test data, for reference only)

| 24 V | | | | | |
|--|-------|-------|-------|-------|-------|
| Battery specification×quantity:12V/200Ah×2 | | | | | |
| Starting temperature | °C | 25 | -15 | -25 | -30 |
| Starting speed | r/min | 186 | 140 | 104 | 97 |
| Starting current | A | 199.2 | 353.7 | 401.1 | 410.5 |
| Starting voltage | V | 20.5 | 20.4 | 18.1 | 17.2 |
| Starting time | s | 1.4 | 7.9 | 3.3 | 10.1 |
| Preheating time | s | 0 | 0 | 30 | 40 |

Auxiliary intake heater

- Type..... Grating-type
- Specification 2.2 kW

Water preheater

- Recommended specification.3 kW/220 V
- Engine preheater water outlet interface (thermostat).... NPT 1/2
- Engine preheater water inlet interface (distributor)..... M14×1.5

Oil heater

- Recommended specification.300 W/220 V
- Interface (oil sump, 1)..... M22×1.5

Exhaust system

- Max. exhaust backpressure..... 10 kPa
- Inner diameter of exhaust port pipe..... Φ125 mm

Noise

Noise data (235 kW @ 1500 r/min)

| Position | Noise Lp, dB(A) |
|----------|-----------------|
| 1 | 91.132 |
| 2 | 97.152 |
| 3 | 91.551 |
| 4 | 96.305 |
| 5 | 91.297 |
| 6 | 96.644 |
| 7 | 91.492 |
| 8 | 91.997 |
| 9 | 98.428 |

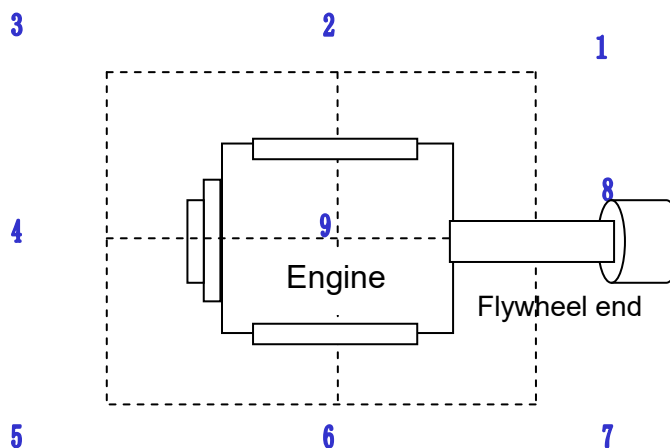

Noise spectrum (235 kW @ 1500 r/min)

| Frequency, Hz | Noise, dB(A) |
|---------------|--------------|
| 63 | 52.5 |
| 125 | 67.5 |
| 250 | 73.7 |
| 500 | 82.7 |
| 1k | 86.5 |
| 2k | 85.9 |
| 4k | 81.2 |
| 8k | 76.3 |
| 16k | 75.4 |

