

YC6MK420L-D20

Prime power: 281 kW @ 1500 r/min

Standby power: 309 kW @ 1500 r/min

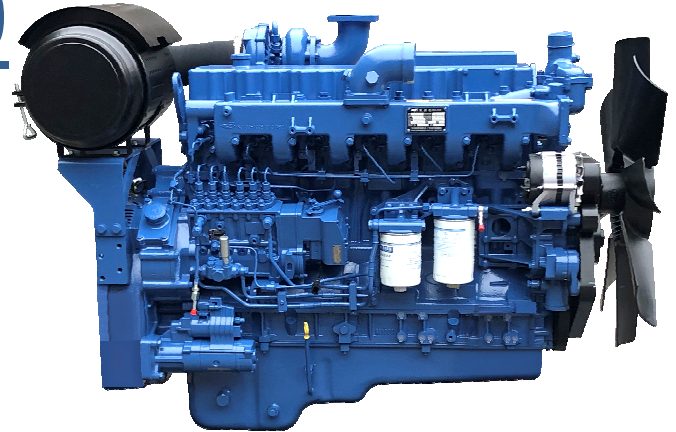

Definitions

Prime Power

It corresponds to the prime rated power (PRP) of GB/T 2820 and ISO 8528, and refers to the maximum power accessible at the variable load for an unlimited running hours per year, with the maintenance intervals and procedures being carried out as prescribed by Yuchai, and the allowed average output power within 24 h shall not be higher than 70% of the prime power.

Standby Power

It corresponds to the emergency standby power (ESP) of GB/T 2820 and ISO 8528, and refers to the maximum power accessible at a certain variable load series in the event of a utility power outage or under test conditions for an limited running hours up to 200 h per year, with the maintenance intervals and procedures being carried out as prescribed by Yuchai. The allowed average output power within 24 h shall not be higher than 70% of the standby power.

Main technical parameters

Number of cylinders	6
Configuration	Vertical, in-line
Aspiration	Turbocharged, air-air intercooled
Combustion system	Direct injection
Compression ratio	16.8:1
Bore	123 mm
Stroke	145 mm
Displacement	10.34 L
Rotation	Counterclockwise (viewed from the flywheel end)
Firing order (viewed from the belt pulley end)	1-5-3-6-2-4
Dry weight (without radiator)	1030 kg
Wet weight (without radiator)	1080 kg

Overall dimensions

Length (from front end of radiator to rear end of air filter)	2088 mm
Width	1130 mm
Height (with radiator and mounting support)	1392 mm

Centre of gravity (dry engine, with the center of the rear end face of the flywheel shell as the origin)

From the rear end face of the flywheel	567 mm
Height relative to the center of the crankshaft	181 mm

Centerline deviation relative to the crankshaft center gravity	-2 mm
--	-------

Moments of rotation inertia

Engine	3.02 kg·m ²
Flywheel	2.35 kg·m ²

Performance rating

Speed droop	≤ 3 %
Steady state speed band	≤ 0.5 %

Test conditions

Ambient temperature	25 °C
Atmospheric pressure	100 kPa
Relative humidity	30 %
Max. operating intake resistance	≤ 5 kPa
Exhaust backpressure limit	≤ 10 kPa
Fuel temperature (fuel inlet pump)	38±2 °C

Attention: Unless otherwise explicitly specified, all parameter data are measured under standard test condition as above. If the engine is operated under other test conditions rather than the test condition above, it shall be adjusted properly according to the actual environment. Contact the Yuchai Technical Service Department for details.

Matching parameters

Designation	Unit	Matching parameters	
		Standby	Prime
		50 Hz @ 1500 r/min	
Gross engine power	kW	309	281
Net engine power	kW	294	266
Fan power consumption (belt pulley driven)	kW	11	11
Other power loss	kW	4	4
Mean effective pressure	MPa	2.39	2.17
Intake air flow	m ³ /min	18.3	17.8
Exhaust temperature limit (after turbocharger)	°C	580	580
Exhaust flow	m ³ /min	48.1	44.5
Boost pressure ratio		3.26	3.09
Thermal efficiency	%	40.2	40.8
Mean piston speed	m/s	7.25	7.25
Coolant flow	L/min	336	336
Cooling fan air flow	m ³ /min	612	612
Typical gen-set electrical output (power factor:0.8)	kW	275	250
	kVA	344	313
Assumed generator efficiency	%	93.5	94.0

Energy balance parameters

Note: The calorific value of diesel is 42,770 kJ/kg

Designation	Unit	Energy balance parameters	
		Standby	Prime
		50 Hz @ 1500 r/min	
Total fuel chemical energy	kW	768	688
Output power (gross)	kW	309	281
Output power (net)	kW	294	266
Fan power consumption	kW	11	11
Other power loss	kW	4	4
Heat dissipation capacity(coolant circulation)	kW	153	146
Heat dissipation capacity(intake intercooled system)	kW	57	51
Heat dissipation of exhaust	kW	226	192
Heat dissipation of thermal radiation	kW	23	18

Heat dissipating capacity of Yuchai engine with MKLF0-1316100 radiator at an ambient temperature of 50°C is as follows:

Designation	Unit	Energy balance parameters	
		Standby	Prime
		50 Hz @ 1500 r/min	
Total fuel chemical energy	kW	780	698
Output power (gross)	kW	309	281
Output power (net)	kW	294	266
Fan power consumption	kW	11	11
Other power loss	kW	4	4
Heat dissipation capacity(coolant circulation)	kW	154	147
Heat dissipation capacity(intake intercooled system)	kW	58	52
Heat dissipation of exhaust	kW	232	197
Heat dissipation of thermal radiation	kW	27	21

Cooling system

Total coolant capacity.....	65 L
Engine coolant capacity.....	21 L
Radiator coolant capacity.....	40 L
Pipeline coolant capacity.....	4 L
Engine max. outlet coolant temperature.....	99℃
Thermostat operation temperature	
Initial open.....	(80±2)℃
full open.....	<90℃
Max. coolant temperature rise:	
-Standby power.....	8.5℃
-Prime power.....	8℃

Radiator

Cooling area.....	114.4m ²
Dry weight.....	155kg
Core material.....	Aluminum
Width of core.....	1050 mm
Height of core.....	1060 mm
Thickness of core.....	96 mm
Min. pressure of pressure cap.....	(50±5)kPa
Coolant resistance limit.....	≤30 kPa

Intercooler

Cooling area.....	53.2 m ²
Core material.....	Aluminum
Width of core.....	1050 mm
Height of core.....	1060 mm
Thickness of core.....	63 mm
Air resistance limit.....	≤10 kPa

Coolant pump

Rotation speed.....	2460 r/min
Drive mode.....	Pulley driven

Fan

Diameter.....	850 mm
Drive ratio.....	1.04:1
Material.....	Engineering plastics
Number of blades.....	8
Type.....	Blowing

Intake system

Air filter

Max. intake resistance:	
-Clean air filter	3.5 kPa
-Dirty air filter	5 kPa
-Warning of intake resistance	6.2 kPa
-Air filter type.....	Dry-type, filter cartridge of paper

Inclination

Transverse inclination/longitudinal inclination (volume of engine oil sump: 28 L)20°/ 15°
---	-----------

Fuel system

Injection system.....Mechanical pump+electronic governor

Injector

Type.....	P-type, with multiple jets
Injector opening pressure	(26~27) MPa

Fuel pump

Drive mode	Gear driven
Fuel delivery pump flow @1,500 rpm	4.1 L/min
Max. fuel inlet temperature limit.....	70 ℃
Allowed fuel inlet pressure of front end of fuel delivery pump (absolute pressure).....	(-100~150) kPa
Maximum fuel return pressure of fuel pump	20 kPa

Fuel filter

Pre- filter

Rated flow.....	7 L/min
Max. original resistance	12 kPa
Water separation efficiency at the rated flow	≥95 %
Filter efficiency:	
For particles of ≥30 μm	≥96 %
For particles of (25~30) μm	≥85 %

Fine- filter

Rated flow.....	7 L/min
Max. original resistance	8 kPa
Filtering efficiency:	
For particles of ≤4 μm	≥98.5 %
For particles of (4~6) μm	≥99.6 %
For particles of (6~14) μm	≥99.9 %
For particles of ≥14 μm	≥99.99 %

Fuel consumption

Note: The density of diesel is 0.835 kg/L.

Load condition	1500 r/min	
	g/(kW·h)	L/h
Standby	209.6	77.6
Prime	203.9	69.1
75% prime	204.7	51.8
50% prime	211.3	35.6

Lubricating system

- Total oil capacity(dry engine)30 L
- Total oil capacity(oil change)28 L
- Oil sump capacity - low level/high level 22/28 L
- Max. oil temperature (in oil sump)120 °C
- Operating oil temperature(in oil sump)..... (90~115) °C
- Oil pressure(idle speed) ≥120 kPa
- Oil pressure(rated speed)..... (300~600) kPa
- Oil-fuel consumption ratio <0.1 %

Oil filter

The filtering efficiency at the rated flow of 60 L/min and the assembly initial resistance ≤25 kPa:

- For 15µm≤particles<20µm.....> 75%
- For 20µm≤particles<30µm.....> 95%
- For 30µm≤particles<40µm.....> 99%
- For particles≥40µm.....> 99.9999%

Electric system

Type.....Negative ground

Charger

- Voltage 28V
- Output current 55A

Starter

- TypeElectric start, 1
- Voltage 24V
- Power9kW
- Number of teeth of flywheel..... 119
- Number of teeth of starter..... 11

Cold start (test data, for reference only)

24 V					
Battery specification×quantity:12V/200Ah×2					
Starting temperature	°C	25	-15	-25	-30
Starting speed	r/min	186	140	104	97
Starting current	A	200	354	402	411
Starting voltage	V	20.5	20.4	18.1	17.2
Starting time	s	1.4	7.9	3.5	10.5
Preheating time	s	0	0	35	50

Auxiliary intake heater

Type..... Grating-type
Specification2.2 kW

Water preheater

Recommended specification.3 kW/220 V
Engine preheater water outlet interface (thermostat).... NPT 1/2
Engine preheater water inlet interface (distributor)..... M14×1.5

Oil heater

Recommended specification.300 W/220 V
Interface (oil sump, 1)..... M22×1.5

Exhaust system

Max. exhaust backpressure..... 10 kPa
Inner diameter of exhaust port pipe..... Φ125 mm

Noise

Noise data (281 kW @ 1500 r/min)

Position	Noise Lp, dB(A)
1	92.179
2	98.366
3	93.064
4	96.735
5	92.590
6	97.403
7	92.855
8	92.542
9	99.074

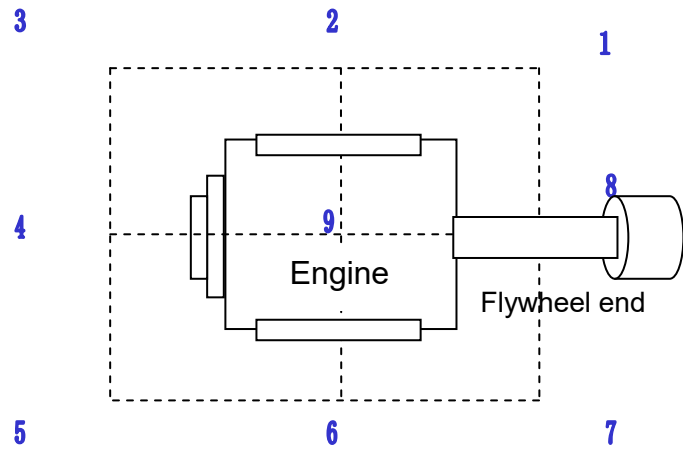

Noise spectrum (281 kW @ 1500 r/min)

Frequency, Hz	Noise, dB(A)
63	53.2
125	68.2
250	74
500	83
1k	87
2k	86
4k	81.6
8k	76.4
16k	75

