

YC6T600L-D22

Prime power: 401 kW @ 1500 r/min

Standby power: 441 kW @ 1500 r/min

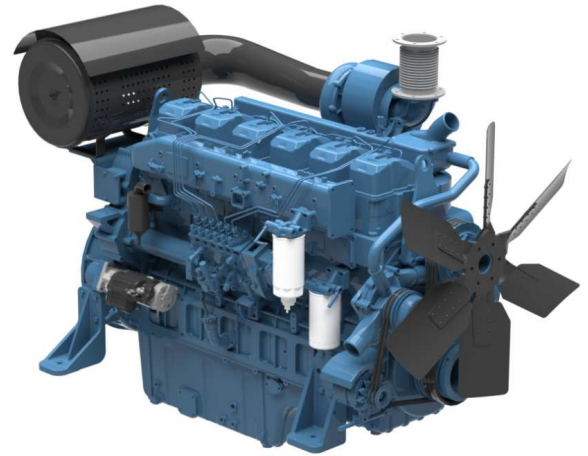

Definitions

Prime Power

It corresponds to the prime rated power (PRP) of GB/T 2820 and ISO 8528, and refers to the maximum power accessible at the variable load for an unlimited running hours per year, with the maintenance intervals and procedures being carried out as prescribed by Yuchai, and the allowed average output power within 24 h shall not be higher than 70% of the prime power.

Standby Power

It corresponds to the emergency standby power (ESP) of GB/T 2820 and ISO 8528, and refers to the maximum power accessible at a certain variable load series in the event of a utility power outage or under test conditions for an limited running hours up to 200 h per year, with the maintenance intervals and procedures being carried out as prescribed by Yuchai. The allowed average output power within 24 h shall not be higher than 70% of the standby power.

Main technical parameters

Number of cylinders	6
Configuration	Vertical, in-line
Aspiration	Turbocharged, air-air intercooled
Combustion system	Direct injection
Compression ratio	15:1
Bore	145 mm
Stroke	165 mm
Displacement	16.35 L
Rotation	Counterclockwise (viewed from the flywheel end)
Firing order (viewed from the belt pulley end)	1-5-3-6-2-4
Dry weight (without radiator)	1980 kg
Wet weight (without radiator)	2078 kg

Overall dimensions

Length (from front end of radiator to rear end of air filter)	2488 mm
Width	1240 mm
Height (with radiator and mounting support)	1688 mm

Centre of gravity (dry engine, with the center of the rear end face of the flywheel shell as the origin)

From the rear end face of the flywheel	824 mm
Height relative to the center of the crankshaft	178 mm

Centerline deviation relative to the crankshaft center gravity	-3.6 mm
--	---------

Moments of rotation inertia

Engine	6.18 kg·m ²
Flywheel	4.04 kg·m ²

Performance rating

Speed droop	≤ 3 %
Steady state speed band	≤ 0.5 %

Test conditions

Ambient temperature	25 °C
Atmospheric pressure	100 kPa
Relative humidity	30 %
Max. operating intake resistance	≤ 5 kPa
Exhaust backpressure limit	≤ 10 kPa
Fuel temperature (fuel inlet pump)	38±2 °C

Attention: Unless otherwise explicitly specified, all parameter data are measured under standard test condition as above. If the engine is operated under other test conditions rather than the test condition above, it shall be adjusted properly according to the actual environment. Contact the Yuchai Technical Service Department for details.

Matching parameters

Designation	Unit	Matching parameters	
		Standby	Prime
		50 Hz @ 1500 r/min	
Gross engine power	kW	441	401
Net engine power	kW	427	387
Fan power consumption (belt pulley driven)	kW	13	13
Other power loss	kW	1	1
Mean effective pressure	MPa	2.16	1.96
Intake air flow	m ³ /min	29.3	28.2
Exhaust temperature limit (after turbocharger)	°C	580	580
Exhaust flow	m ³ /min	72.5	66.6
Boost pressure ratio		3.28	3.08
Thermal efficiency	%	40.5	41.2
Mean piston speed	m/s	8.25	8.25
Coolant flow	L/min	490	490
Cooling fan air flow	m ³ /min	628	628
Typical gen-set electrical output (power factor:0.8)	kW	400	360
	kVA	500	450
Assumed generator efficiency	%	93.7	93.0

Energy balance parameters

Note: The calorific value of diesel is 42,770 kJ/kg

Designation	Unit	Energy balance parameters	
		Standby	Prime
		50 Hz @ 1500 r/min	
Total fuel chemical energy	kW	1088	975
Output power (gross)	kW	441	401
Output power (net)	kW	427	387
Fan power consumption	kW	13	13
Other power loss	kW	1	1
Heat dissipation capacity(coolant circulation)	kW	212	202
Heat dissipation capacity(intake intercooled system)	kW	123	110
Heat dissipation of exhaust	kW	283	237
Heat dissipation of thermal radiation	kW	29	25

Heat dissipating capacity of Yuchai engine with T9650-1316100 radiator at an ambient temperature of 50°C is as follows:

Designation	Unit	Energy balance parameters	
		Standby	Prime
		50 Hz @ 1500 r/min	
Total fuel chemical energy	kW	1123	1012
Output power (gross)	kW	441	401
Output power (net)	kW	427	387
Fan power consumption	kW	13	13
Other power loss	kW	1	1
Heat dissipation capacity(coolant circulation)	kW	218	207
Heat dissipation capacity(intake intercooled system)	kW	132	121
Heat dissipation of exhaust	kW	299	255
Heat dissipation of thermal radiation	kW	31	28

Cooling system

Total coolant capacity.....	89 L
Engine coolant capacity.....	36 L
Radiator coolant capacity.....	48 L
Pipeline coolant capacity.....	5 L
Engine max. outlet coolant temperature.....	99℃
Thermostat operation temperature	
Initial open.....	(75±2)℃
full open.....	(85±2)℃
Max. coolant temperature rise:	
-Standby power.....	8.0℃
-Prime power.....	7.8℃

Radiator & Intercooler

(drawing number: T9650-1316100)

Dry weight.....	269kg
-----------------	-------

Radiator

Cooling area.....	142.1m ²
Core material.....	Aluminum
Width of core.....	1368 mm
Height of core.....	1140 mm
Thickness of core.....	82 mm
Min. pressure of pressure cap.....	(50±5)kPa
Coolant resistance limit.....	15 kPa

Intercooler

Cooling area.....	66.8 m ²
Core material.....	Aluminum
Width of core.....	1354 mm
Height of core.....	1125 mm
Thickness of core.....	62 mm
Air resistance limit.....	12.5 kPa

Coolant pump

Rotation speed.....	2631 r/min
Drive mode.....	Pulley driven

Fan

Diameter.....	965 mm
Drive ratio.....	0.935:1
Material.....	Steel
Number of blades.....	6
Type.....	Blowing

Intake system

Air filter

Max. intake resistance:	
-Clean air filter	3.5 kPa
-Dirty air filter	5 kPa
-Warning of intake resistance	6.2 kPa
-Air filter type.....	Dry-type, filter cartridge of paper
Rated flow.....	2100m ³ /h

Inclination

Transverse inclination/longitudinal inclination (volume of engine oil sump: 52 L)	10°/ 10°
---	----------

Fuel system

Injection system.....	Mechanical pump+electronic governor
-----------------------	-------------------------------------

Injector

Type.....	P-type
Injector opening pressure	(24~25) MPa

Fuel pump

Drive mode	Gear driven
Fuel delivery pump flow @1,500 rpm	10 L/min
Max. fuel inlet temperature limit.....	70 °C
Allowed fuel inlet pressure of front end of fuel delivery pump (absolute pressure).....	(-100~150) kPa
Maximum fuel return pressure of fuel pump	20 kPa

Fuel filter

Pre- filter

Rated flow.....	7 L/min
Max. original resistance	12 kPa
Water separation efficiency at the rated flow	≥95 %
Filter efficiency:	
For particles of 25 μm.....	≥99 %
For particles of 10 μm.....	≥85 %

Fine- filter

Rated flow.....	7 L/min
Max. original resistance	10 kPa
Filtering efficiency:	
For particles of 14 μm.....	≥99.999 %
For particles of 6 μm.....	≥99.9 %
For particles of 4 μm.....	≥96.6 %

Fuel consumption

Note: The density of diesel is 0.835 kg/L.

Load condition	1500 r/min	
	g/(kW·h)	L/h
Standby	207.8	109.7
Prime	204.5	98.2
75% prime	202.1	72.7
50% prime	208.2	50.5

Lubricating system

- Total oil capacity(dry engine)56 L
- Total oil capacity(oil change)52 L
- Oil sump capacity - low level/high level48/56 L
- Max. oil temperature (in oil sump)110 °C
- Operating oil temperature(in oil sump)..... (90~110) °C
- Oil pressure(idle speed) ≥100 kPa
- Oil pressure(rated speed)..... (250~500) kPa
- Oil-fuel consumption ratio..... <0.1 %

Oil filter

- The filtering efficiency at the rated flow of 180 L/min and the assembly initial resistance ≤50 kPa:
- For 15µm≤particles<20µm.....>75%
 - For 20µm≤particles<30µm.....>95%
 - For 30µm≤particles<40µm.....>99%
 - For particles≥40µm.....>99.9999%

Electric system

Type.....Negative ground

Charger

- Voltage 28V
- Output current 27A

Starter

- Type Electric start, 1
- Voltage 24V
- Power9kW
- Number of teeth of flywheel..... 123
- Number of teeth of starter..... 11

Cold start (test data, for reference only)

24 V					
Battery specification×quantity:12V/200Ah×2					
Starting temperature	°C	25	-15	-25	-30
Starting speed	r/min	176	168	118	/
Starting current	A	433	339	570	/
Starting voltage	V	19.8	19.4	17	/
Starting time	s	1.4	20	26	/
Preheating time	s	0	0	30	/

Auxiliary intake heater

- Type..... Grating-type
- Specification3.9 kW

Water preheater

- Recommended specification.4 kW/220 V
- Engine preheater water outlet interface (thermostat).... NPT 3/4
- Engine preheater water inlet interface (distributor)..... M18×1.5

Oil heater

- Recommended specification.300 W/220 V
- Interface (oil sump, 1)..... M22×1.5

Exhaust system

- Max. exhaust backpressure..... 10 kPa
- Inner diameter of exhaust port pipe.....Φ125 mm

Noise

Noise data (401 kW @ 1500 r/min)

Position	Noise, dB(A)
1	97.3
2	106.5
3	95.9
4	99.4
5	94.3
6	94.1
7	93.7
8	97.1
9	99.6

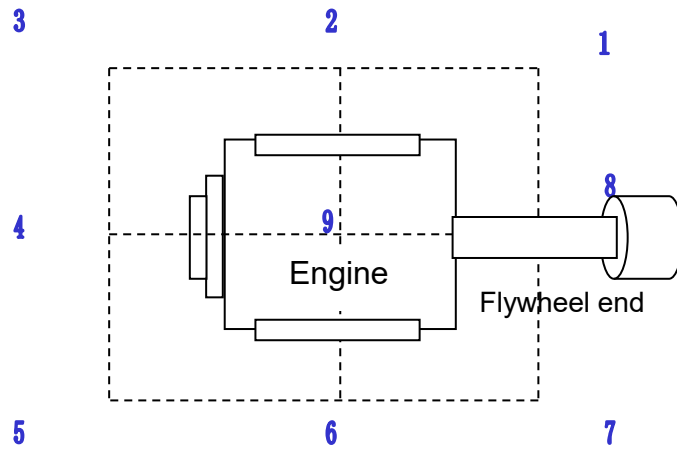

Noise spectrum (401 kW @ 1500 r/min)

Frequency, Hz	Noise, dB(A)
63	48.6
125	62.6
250	76.1
500	84.6
1k	89.3
2k	89.5
4k	85.7
8k	81.8
16k	69.9

