

# YC6T660-D31

Prime power: 441 kW @ 1500 r/min

Standby power: 485 kW @ 1500 r/min

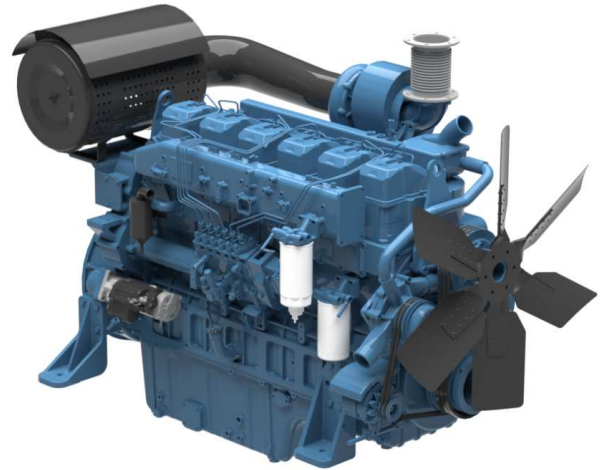

## Definitions

### Prime Power

It corresponds to the prime rated power (PRP) of GB/T 2820 and ISO 8528, and refers to the maximum power accessible at the variable load for an unlimited running hours per year, with the maintenance intervals and procedures being carried out as prescribed by Yuchai, and the allowed average output power within 24 h shall not be higher than 70% of the prime power.

### Standby Power

It corresponds to the emergency standby power (ESP) of GB/T 2820 and ISO 8528, and refers to the maximum power accessible at a certain variable load series in the event of a utility power outage or under test conditions for an limited running hours up to 200 h per year, with the maintenance intervals and procedures being carried out as prescribed by Yuchai. The allowed average output power within 24 h shall not be higher than 70% of the standby power.

## Main technical parameters

Number of cylinders .....	6
Configuration .....	Vertical, in-line
Aspiration .....	Turbocharged, air-air intercooled
Combustion system .....	Direct injection
Compression ratio .....	15:1
Bore .....	145 mm
Stroke .....	165 mm
Displacement .....	16.35 L
Rotation .....	Counterclockwise (viewed from the flywheel end)
Firing order (viewed from the belt pulley end) .....	1-5-3-6-2-4
Dry weight (without radiator) .....	1980 kg
Wet weight (without radiator) .....	2180kg

## Overall dimensions

Length (from front end of radiator to rear end of air filter) .....	2488 mm
Width .....	1240 mm
Height (with radiator and mounting support) .....	1688 mm

## Centre of gravity (dry engine, with the center of the rear end face of the flywheel shell as the origin)

From the rear end face of the flywheel .....	824 mm
Height relative to the center of the crankshaft .....	178 mm

Centerline deviation relative to the crankshaft center gravity .....	-3.6 mm
--	---------

## Moments of rotation inertia

Engine .....	6.18 kg·m <sup>2</sup>
Flywheel .....	4.04 kg·m <sup>2</sup>

## Performance rating

Speed droop .....	≤ 1 %
Steady state speed band .....	≤ 0.5 %

## Test conditions

Ambient temperature .....	25 °C
Atmospheric pressure .....	100 kPa
Relative humidity .....	30 %
Max. operating intake resistance .....	≤ 5 kPa
Exhaust backpressure limit .....	≤ 10 kPa
Fuel temperature (fuel inlet pump) .....	38±2 °C

**Attention: Unless otherwise explicitly specified, all parameter data are measured under standard test condition as above. If the engine is operated under other test conditions rather than the test condition above, it shall be adjusted properly according to the actual environment. Contact the Yuchai Technical Service Department for details.**

**Matching parameters**

Designation	Unit	Matching parameters	
		Standby	Prime
		50 Hz @ 1500 r/min	
Gross engine power	kW	485	441
Net engine power	kW	471	427
Fan power consumption (belt pulley driven)	kW	13	13
Other power loss	kW	1	1
Mean effective pressure	MPa	2.37	2.16
Intake air flow	m <sup>3</sup> /min	32.1	29.2
Exhaust temperature limit (after turbocharger)	°C	570	554
Exhaust flow	m <sup>3</sup> /min	82.52	75.4
Boost pressure ratio		2.51	2.17
Thermal efficiency	%	37.3	37.7
Mean piston speed	m/s	8.25	8.25
Coolant flow	L/min	514	514
Cooling fan air flow	m <sup>3</sup> /min	622.2	622.2
Typical gen-set electrical output (power factor:0.8)	kW	440	400
	kVA	550	500
Assumed generator efficiency	%	93.4	93.7

**Energy balance parameters**

**Note:** The calorific value of diesel is 42,770 kJ/kg

Designation	Unit	Energy balance parameters	
		Standby	Prime
		50 Hz @ 1500 r/min	
Total fuel chemical energy	kW	1255	1128
Output power (gross)	kW	485	441
Output power (net)	kW	471	427
Fan power consumption	kW	13	13
Other power loss	kW	1	1
Heat dissipation capacity(coolant circulation)	kW	235	223
Heat dissipation capacity(intake intercooled system)	kW	131	122
Heat dissipation of exhaust	kW	369	309
Heat dissipation of thermal radiation	kW	35	33

Heat dissipating capacity of Yuchai engine with T9650-1316100A radiator at an ambient temperature of 50°C is as follows:

Designation	Unit	Energy balance parameters	
		Standby	Prime
		50 Hz @ 1500 r/min	
Total fuel chemical energy	kW	1278	1150
Output power (gross)	kW	485	441
Output power (net)	kW	471	427
Fan power consumption	kW	13	13
Other power loss	kW	1	1
Heat dissipation capacity(coolant circulation)	kW	239	228
Heat dissipation capacity(intake intercooled system)	kW	136	127
Heat dissipation of exhaust	kW	380	319
Heat dissipation of thermal radiation	kW	38	35

### Cooling system

Total coolant capacity.....	88 L
Engine coolant capacity.....	34L
Radiator coolant capacity.....	48 L
Pipeline coolant capacity.....	6 L
Engine max. outlet coolant temperature.....	99°C
Thermostat operation temperature	
Initial open.....	(75±2)°C
full open.....	(85±2)°C
Max. coolant temperature rise:	
-Standby power.....	8.5°C
-Prime power.....	7°C

### Radiator & Intercooler

Dry weight.....	269kg
-----------------	-------

### Radiator

Cooling area.....	142.1m <sup>2</sup>
Core material.....	Aluminum
Width of core.....	1368 mm
Height of core.....	1140 mm
Thickness of core.....	82 mm
Min. pressure of pressure cap.....	(50±5)kPa
Coolant resistance limit.....	30kPa

### Intercooler

Cooling area.....	66.8 m <sup>2</sup>
Core material.....	Aluminum
Width of core.....	1354 mm
Height of core.....	1125 mm
Thickness of core.....	62 mm
Air resistance limit.....	12.5 kPa

### Coolant pump

Rotation speed.....	2631 r/min
Drive mode.....	Pulley driven

### Fan

Diameter.....	965 mm
Drive ratio.....	0.935:1
Material.....	Steel
Number of blades.....	6
Type.....	Blowing

### Intake system

#### Air filter

Max. intake resistance:	
-Clean air filter .....	3.5 kPa
-Dirty air filter .....	5 kPa
-Warning of intake resistance .....	6.2 kPa
-Air filter type.....	Dry-type, filter cartridge of paper
Rated flow.....	2100m <sup>3</sup> /h

### Inclination

Transverse inclination/longitudinal inclination (volume of engine oil sump: 52 L) .....	10°/ 10°
---	----------

### Fuel system

Injection system.....	Electronic unit pump
-----------------------	----------------------

### Injector

Type.....	Mechanical
Injector opening pressure .....	(24~25) MPa

### Fuel pump

Drive mode .....	Gear driven
Fuel delivery pump flow @1,500 rpm .....	7 L/min
Max. fuel inlet temperature limit.....	70 °C
Allowed fuel inlet pressure of front end of fuel delivery pump (absolute pressure).....	(35~100) kPa
Maximum fuel return pressure of fuel pump .....	20 kPa

### Fuel filter

#### Pre- filter

Rated flow.....	7 L/min
Max. original resistance .....	12 kPa
Water separation efficiency at the rated flow .....	≥95 %
Filter efficiency:	
For particles of 25 μm.....	≥99 %
For particles of 10 μm.....	≥85 %

#### Fine- filter

Rated flow.....	7 L/min
Max. original resistance .....	8 kPa
Filtering efficiency:	
For particles of 14 μm.....	≥99.999 %
For particles of 6 μm.....	≥98.9 %
For particles of 4 μm.....	≥98.5%

### Fuel consumption

**Note:** The density of diesel is 0.835 kg/L.

Load condition	1500 r/min	
	g/(kW·h)	L/h
Standby	217.9	126.5
Prime	215.5	113.8
75% prime	218.4	86.5
50% prime	226.3	59.7

### Lubricating system

Total oil capacity(dry engine) .....56 L  
 Total oil capacity(oil change) .....52 L  
 Oil sump capacity - low level/high level .....39/56 L  
 Max. oil temperature (in oil sump) .....110 °C  
 Operating oil temperature(in oil sump)..... (90~110) °C  
 Oil pressure(idle speed) ..... ≥100 kPa  
 Oil pressure(rated speed)..... (250~500) kPa  
 Oil-fuel consumption ratio..... <0.1 %

### Oil filter

The filtering efficiency at the rated flow of 180 L/min and the assembly initial resistance ≤50 kPa:  
 For 15µm≤particles<20µm.....>75%  
 For 20µm≤particles<30µm.....>95%  
 For 30µm≤particles<40µm.....>99%  
 For particles≥40µm.....>99.9999%

### Electric system

Type.....Negative ground

#### Charger

Voltage ..... 28V  
 Output current ..... 27A

#### Starter

Type ..... Electric start, 1  
 Voltage ..... 24V  
 Power .....9kW  
 Number of teeth of flywheel..... 123  
 Number of teeth of starter..... 11

### Cold start (test data, for reference only)

24 V				
Battery specification×quantity:12V/200Ah×2				
Starting temperature	°C	25	-15	-25
Starting speed	r/min	176	168	118
Starting current	A	433	339	570
Starting voltage	V	19.8	19.4	17
Starting time	s	1.4	20	26
Preheating time	s	0	0	30

### Auxiliary intake heater

Type..... Grating-type  
 Specification .....3.9 kW

### Water preheater

Recommended specification. ....4 kW/220 V  
 Engine preheater water outlet interface..... NPT 3/4  
 Engine preheater water inlet interface ..... M18×1.5

### Oil heater

Recommended specification. ....300 W/220 V  
 Interface (oil sump, 1)..... M22×1.5

### Exhaust system

Max. exhaust backpressure..... 10 kPa  
 Inner diameter of exhaust port pipe.....Φ125 mm

## Noise

Noise data (441 kW @ 1500 r/min)

Position	Noise, dB(A)
1	/
2	/
3	/
4	/
5	/
6	/
7	/
8	/
9	/

